

S-F

INTERIOR 382 SF | EXTERIOR 60 SF
STUDIO, 1 BATH

FORÊT™

FOREST HILL

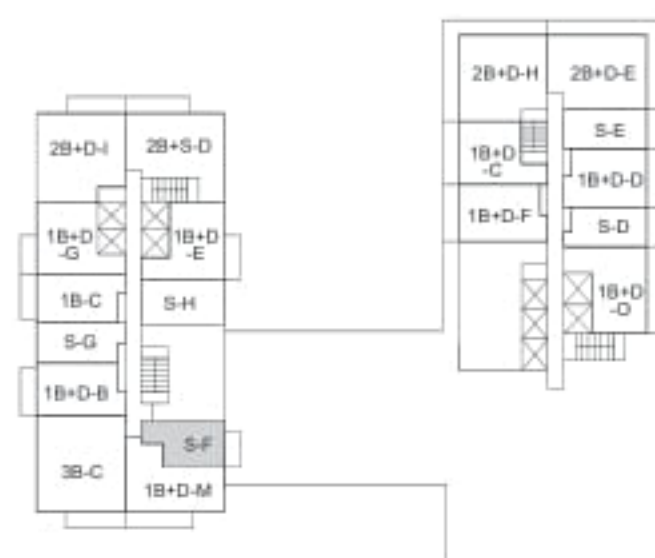
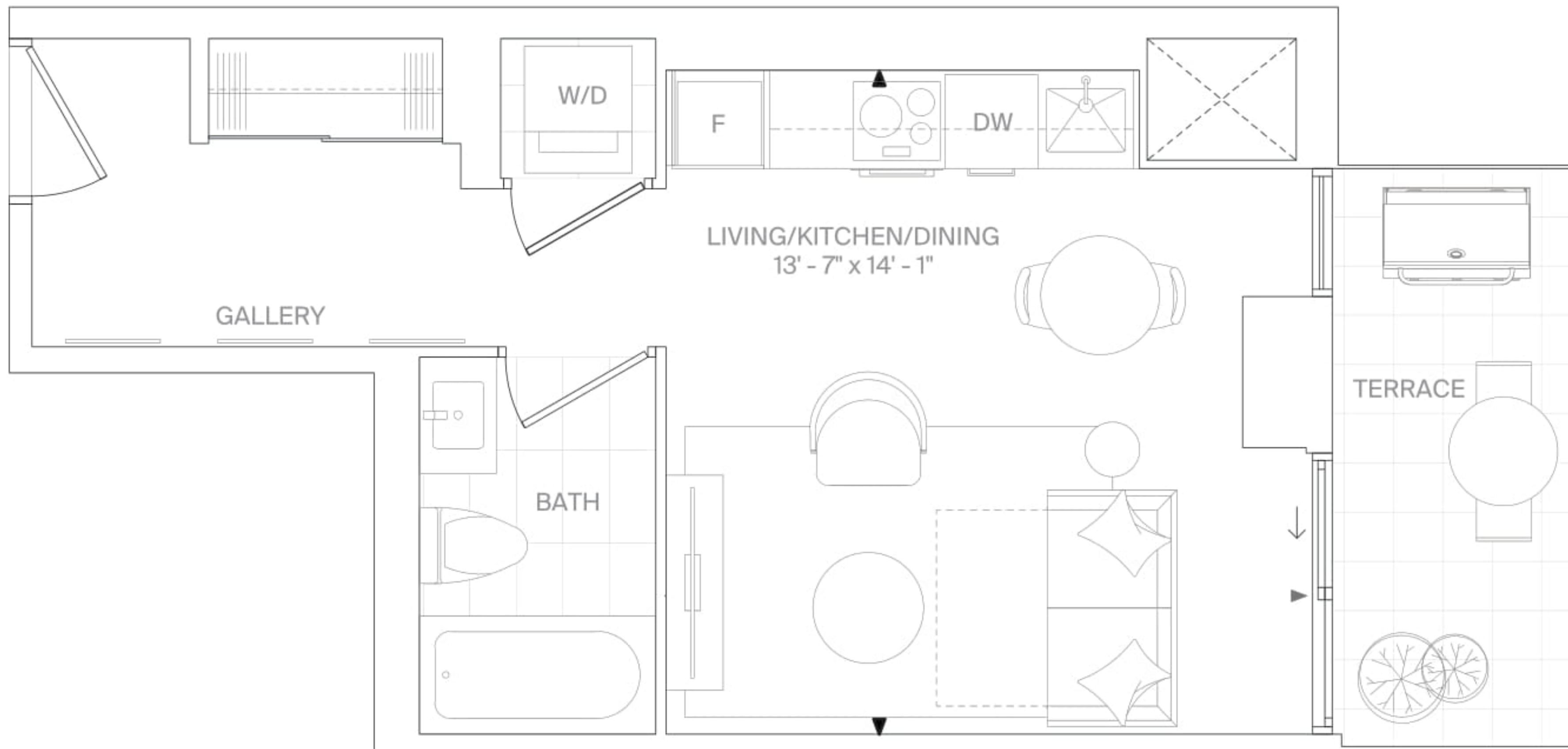

PODIUM LEVEL 9

ALL DIMENSIONS AND SPECIFICATIONS ARE APPROXIMATE. CERTAIN PLANS ARE REVERSE OR MIRROR IMAGE. BALCONY SQUARE FOOTAGES ARE ESTIMATED AND MAY VARY FROM THAT STATED. PLEASE SEE SALES REPRESENTATIVE FOR DETAILS. FURNITURE NOT INCLUDED. REFER TO KEY PLAN FOR UNIT LOCATION AND ORIENTATION. PREPARED JUNE 9, 2022

S-G

INTERIOR 398 SF
STUDIO, 1 BATH

FORÊT™

FOREST HILL

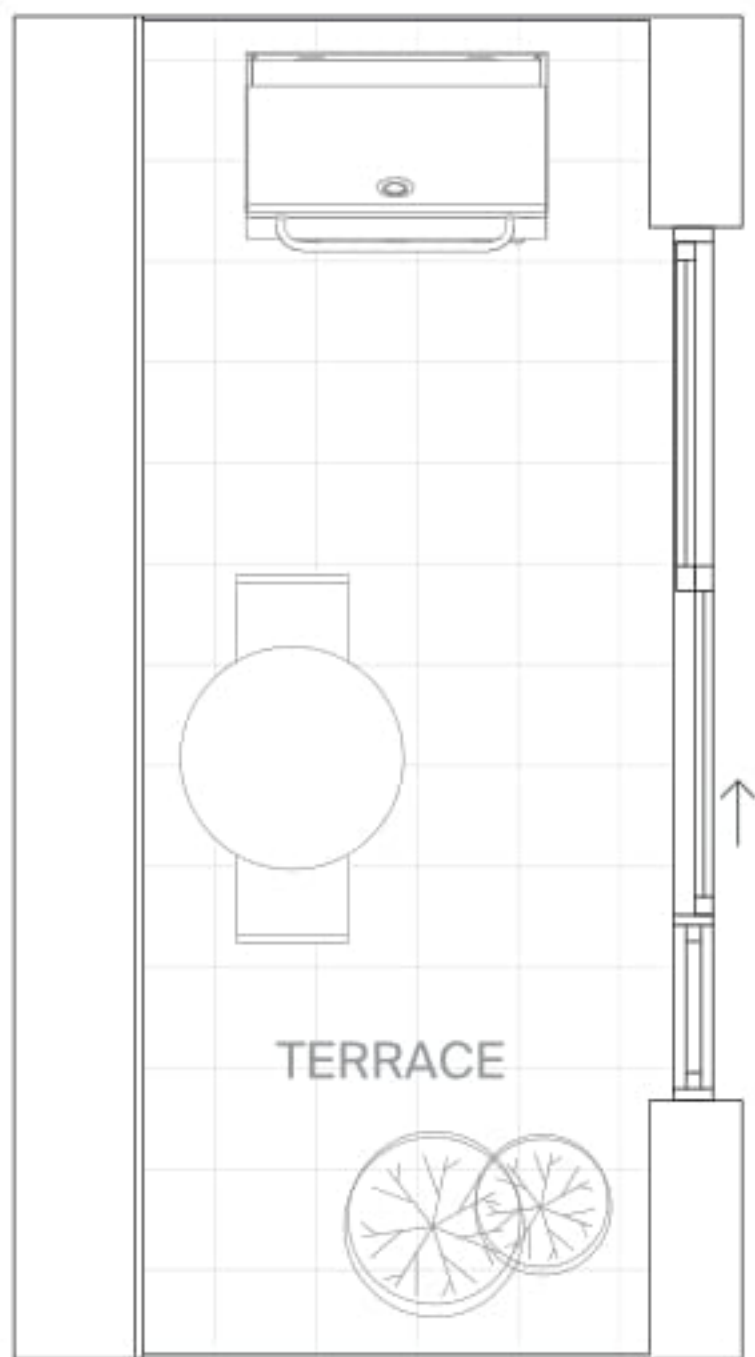

LEVEL 6 EXTERIOR 80 SF

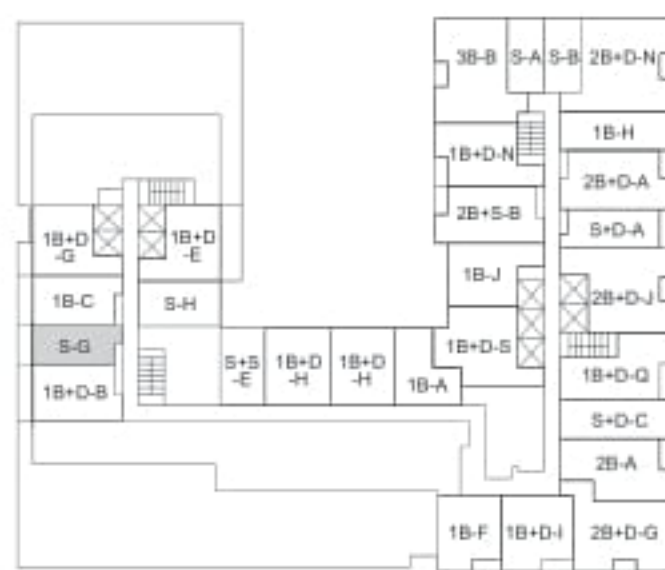
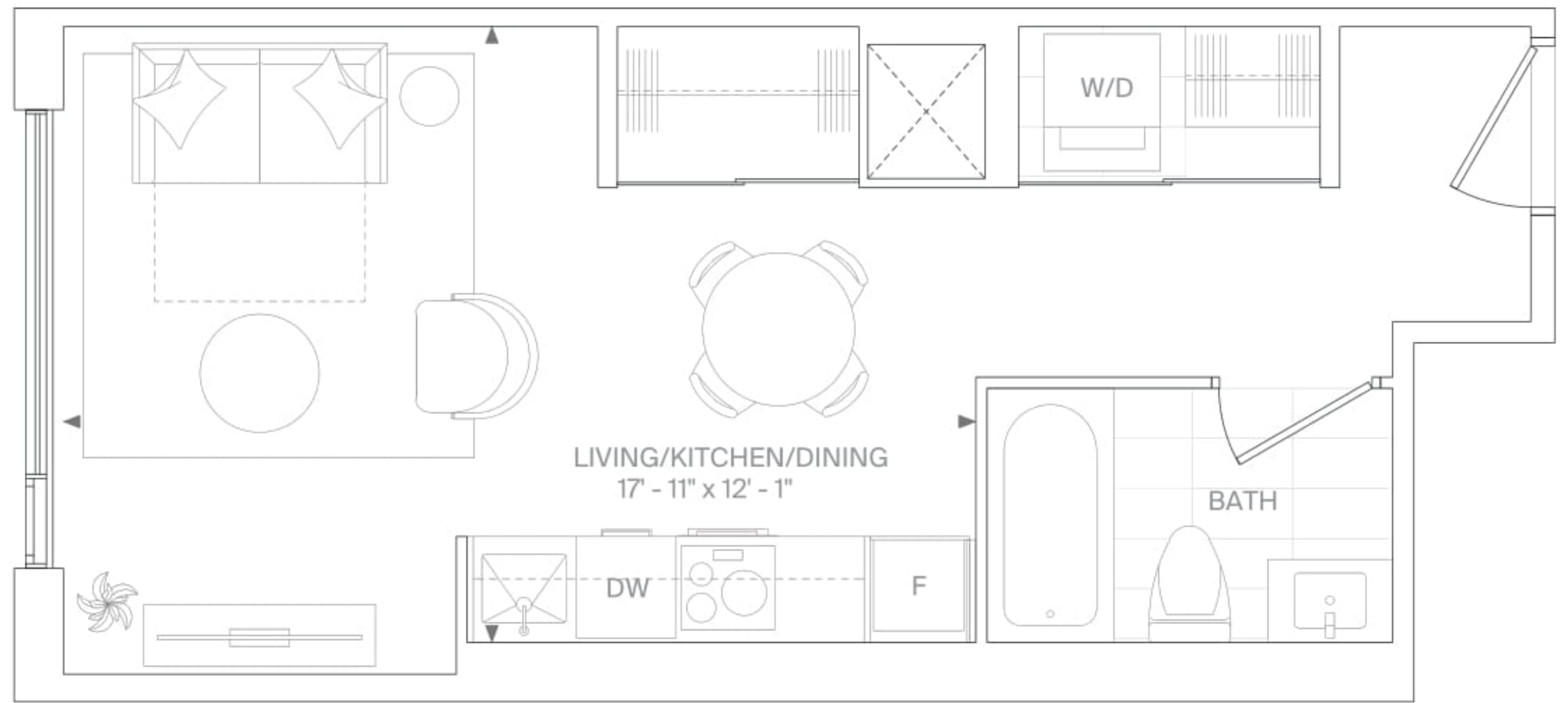

PODIUM LEVEL 6

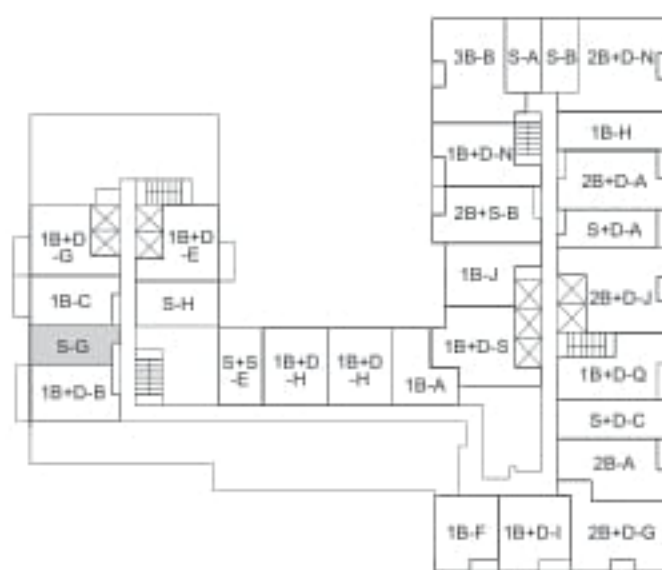

PODIUM LEVEL 7

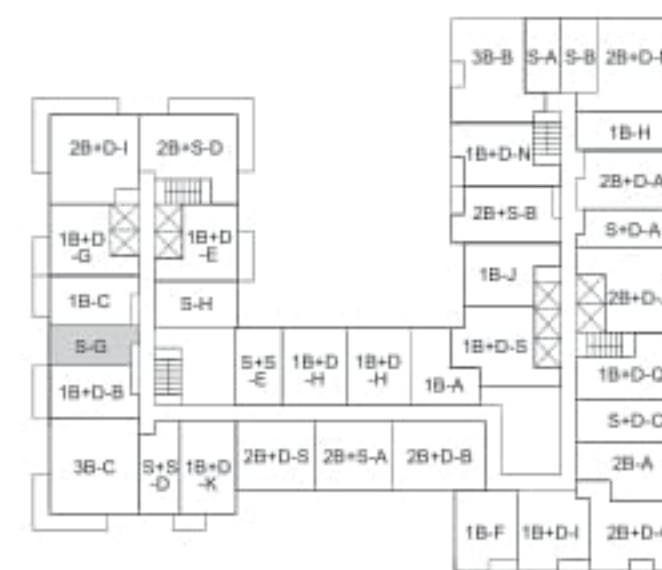

PODIUM LEVEL 8

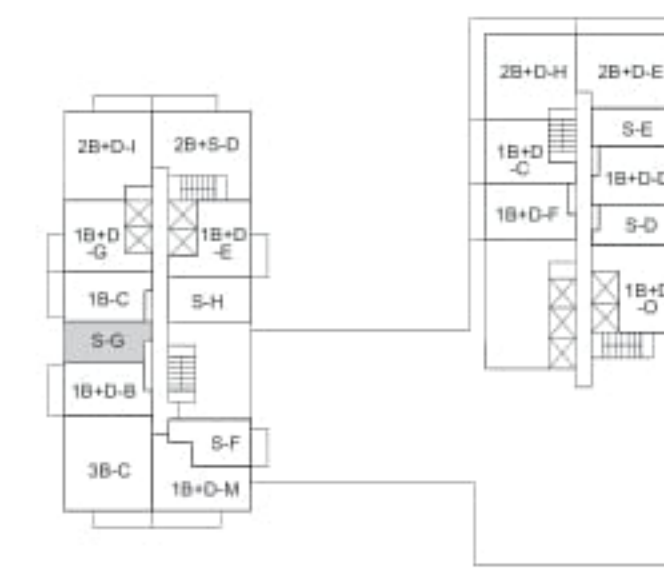

PODIUM LEVEL 9

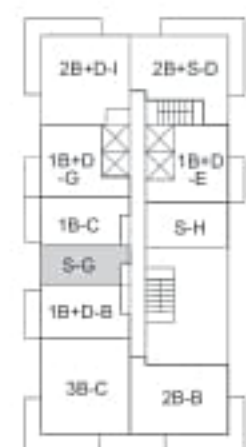

TOWER 2 LEVEL 10



TOWER 2 LEVEL 11



TOWER 2 LEVEL 12 - 29

ALL DIMENSIONS AND SPECIFICATIONS ARE APPROXIMATE. CERTAIN PLANS ARE REVERSE OR MIRROR IMAGE. BALCONY SQUARE FOOTAGES ARE ESTIMATED AND MAY VARY FROM THAT STATED. PLEASE SEE SALES REPRESENTATIVE FOR DETAILS. FURNITURE NOT INCLUDED. REFER TO KEY PLAN FOR UNIT LOCATION AND ORIENTATION. PREPARED JUNE 9, 2022

S-H

INTERIOR 420 SF
STUDIO (BF), 1 BATH

FORÊT™

FOREST HILL

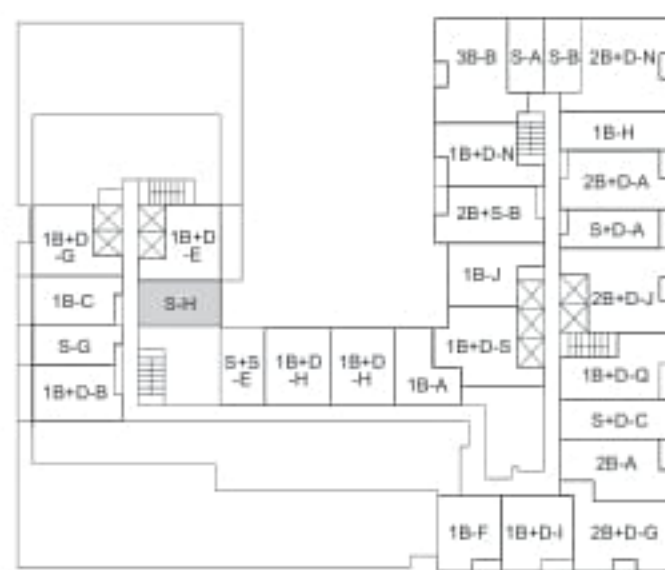
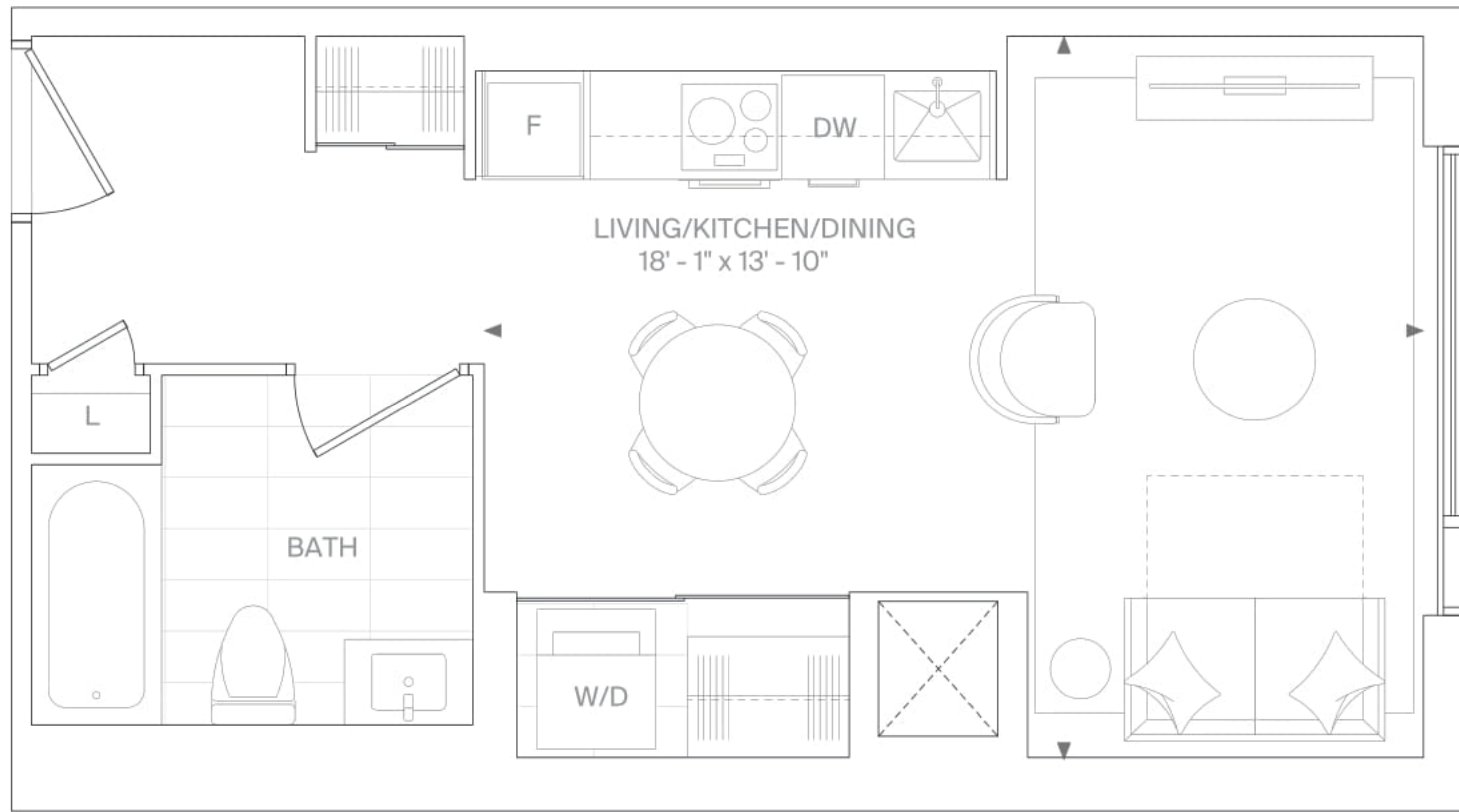

PODIUM LEVEL 6

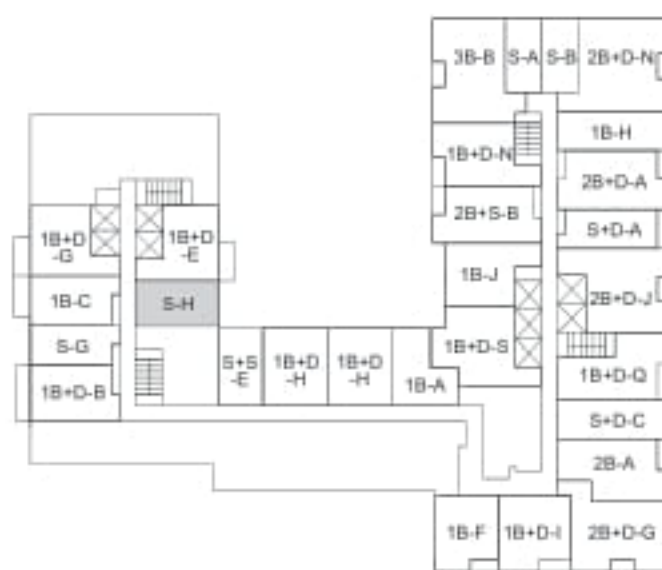

PODIUM LEVEL 7

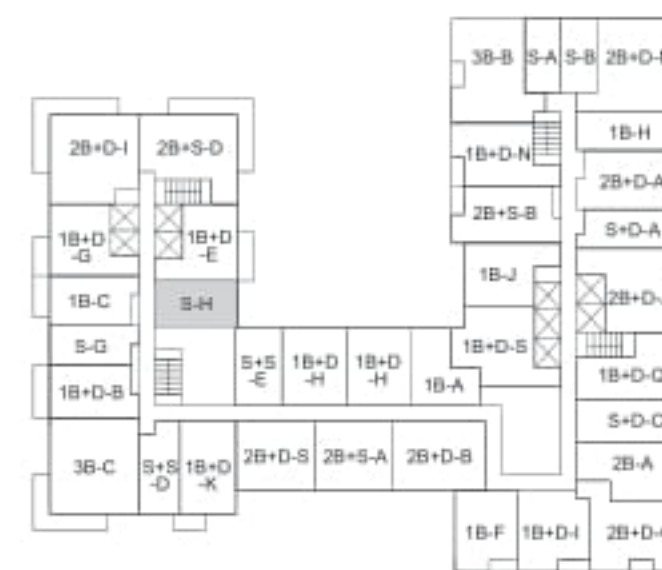

PODIUM LEVEL 8

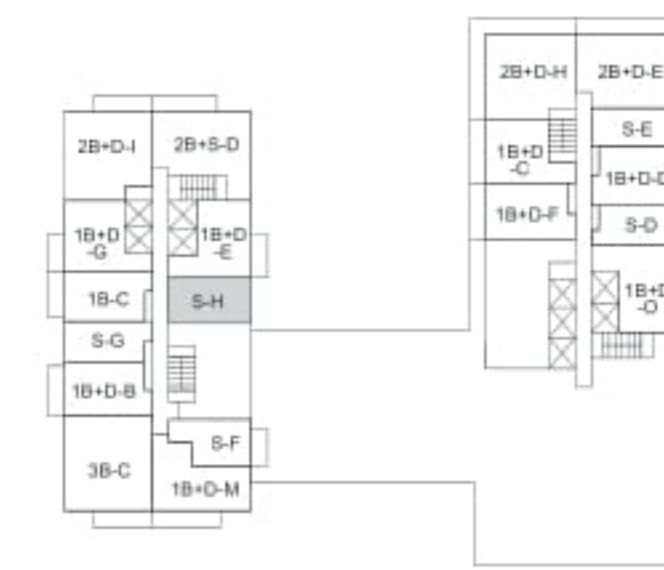

PODIUM LEVEL 9

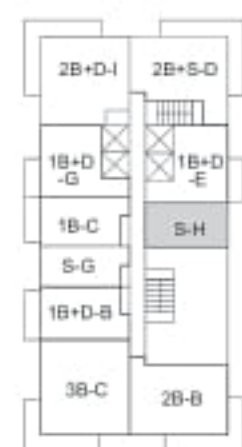

TOWER 2 LEVEL 10

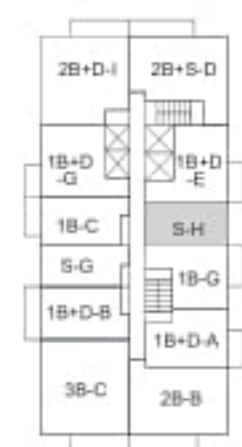

TOWER 2 LEVEL 11

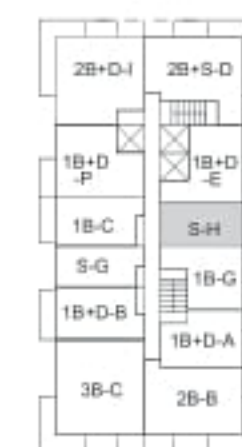

TOWER 2 LEVEL 12 - 29

ALL DIMENSIONS AND SPECIFICATIONS ARE APPROXIMATE. CERTAIN PLANS ARE REVERSE OR MIRROR IMAGE. BALCONY SQUARE FOOTAGES ARE ESTIMATED AND MAY VARY FROM THAT STATED. PLEASE SEE SALES REPRESENTATIVE FOR DETAILS. FURNITURE NOT INCLUDED. REFER TO KEY PLAN FOR UNIT LOCATION AND ORIENTATION. PREPARED JUNE 9, 2022

S+S-A

INTERIOR 369 SF | EXTERIOR 41 SF
STUDIO+STUDY, 1 BATH

FORÊT™

FOREST HILL

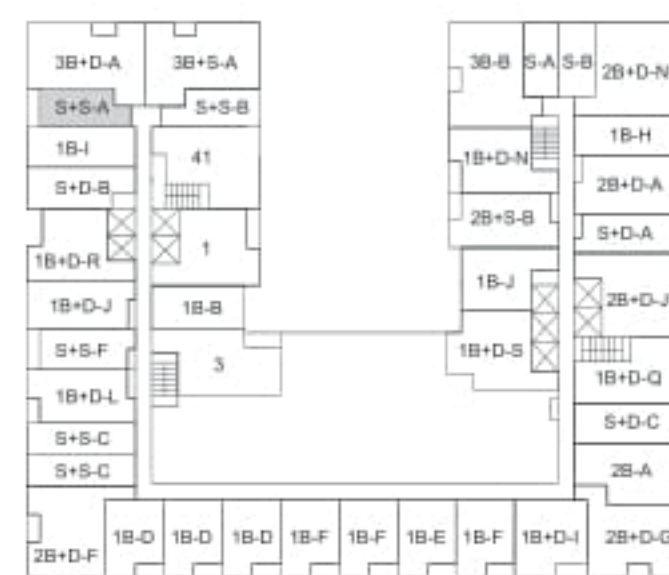
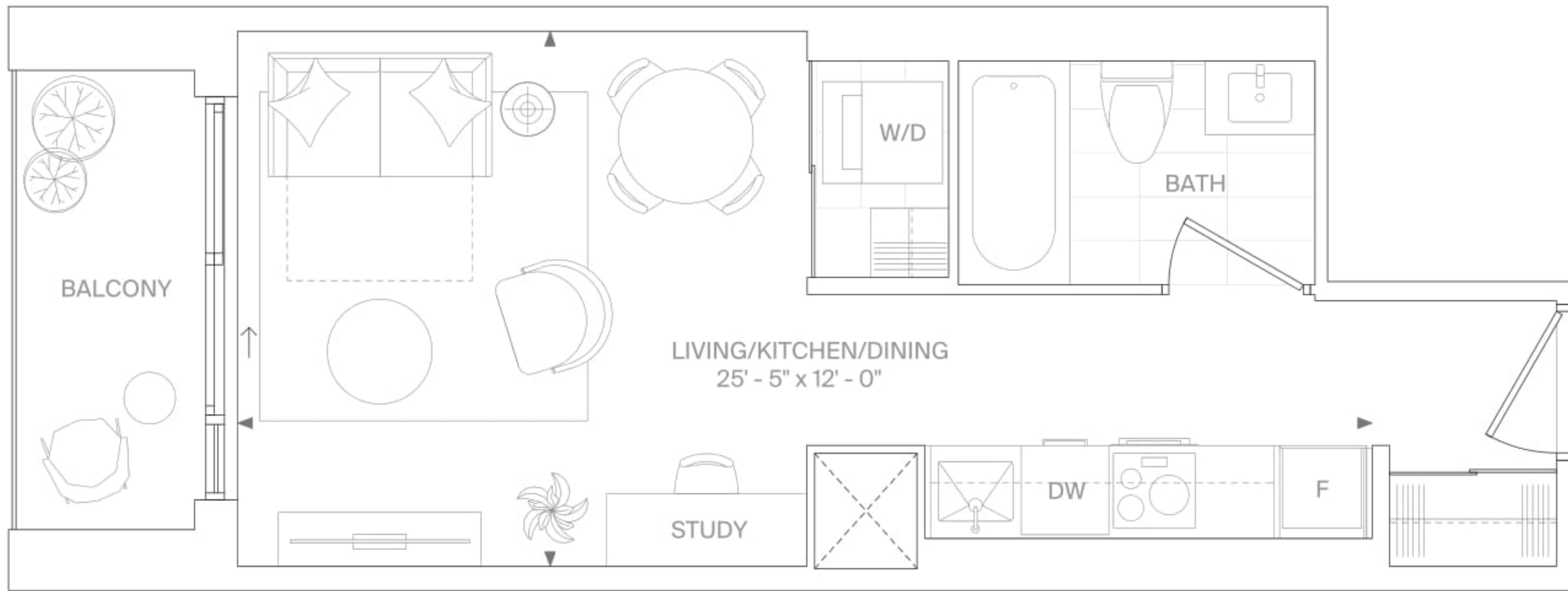

PODIUM LEVEL 3 - 5

ALL DIMENSIONS AND SPECIFICATIONS ARE APPROXIMATE. CERTAIN PLANS ARE REVERSE OR MIRROR IMAGE. BALCONY SQUARE FOOTAGES ARE ESTIMATED AND MAY VARY FROM THAT STATED. PLEASE SEE SALES REPRESENTATIVE FOR DETAILS. FURNITURE NOT INCLUDED. REFER TO KEY PLAN FOR UNIT LOCATION AND ORIENTATION. PREPARED JUNE 9, 2022

S+S-B

INTERIOR 385 SF
STUDIO+STUDY, 1 BATH

FORÊT™

FOREST HILL

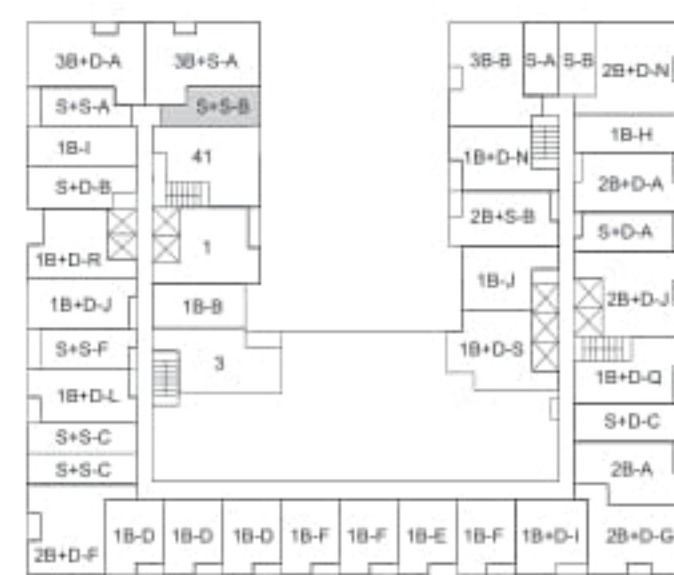
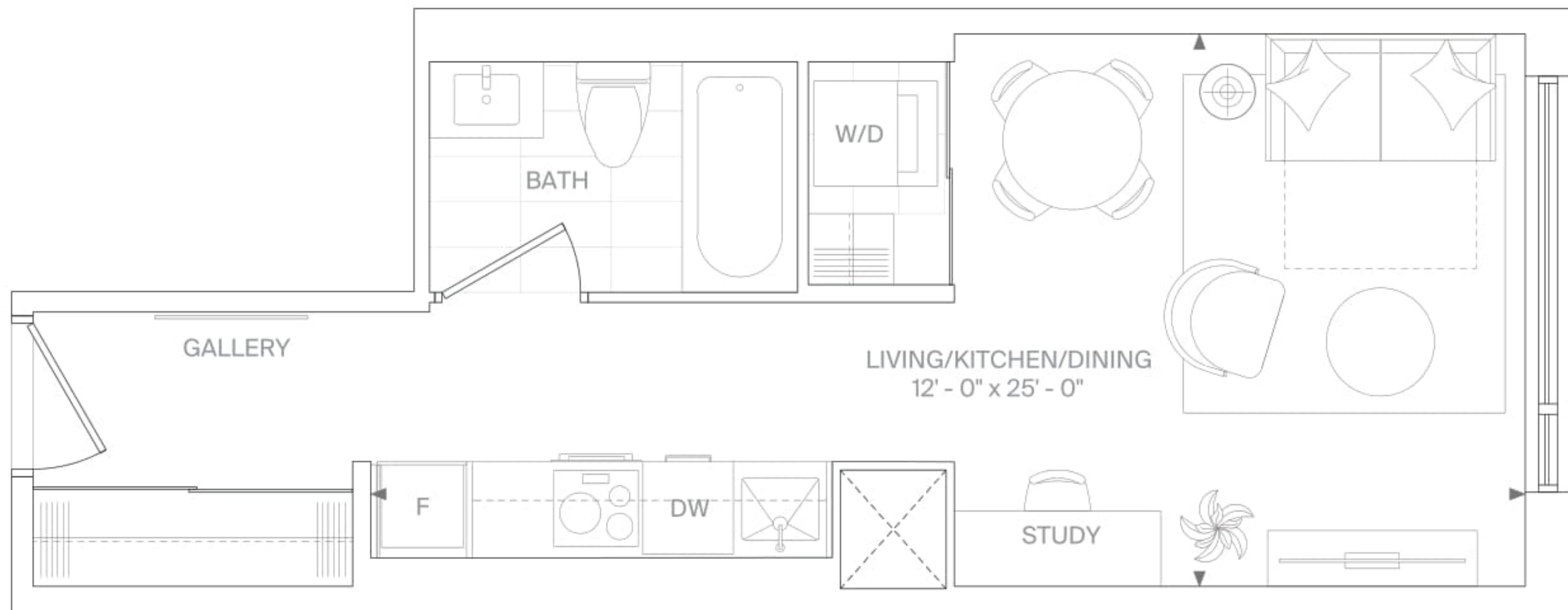

PODIUM LEVEL 3 - 5

ALL DIMENSIONS AND SPECIFICATIONS ARE APPROXIMATE. CERTAIN PLANS ARE REVERSE OR MIRROR IMAGE. BALCONY SQUARE FOOTAGES ARE ESTIMATED AND MAY VARY FROM THAT STATED. PLEASE SEE SALES REPRESENTATIVE FOR DETAILS. FURNITURE NOT INCLUDED. REFER TO KEY PLAN FOR UNIT LOCATION AND ORIENTATION. PREPARED JUNE 9, 2022

S+S-C

INTERIOR 393 SF
STUDIO+STUDY, 1 BATH

FORÊT™

FOREST HILL

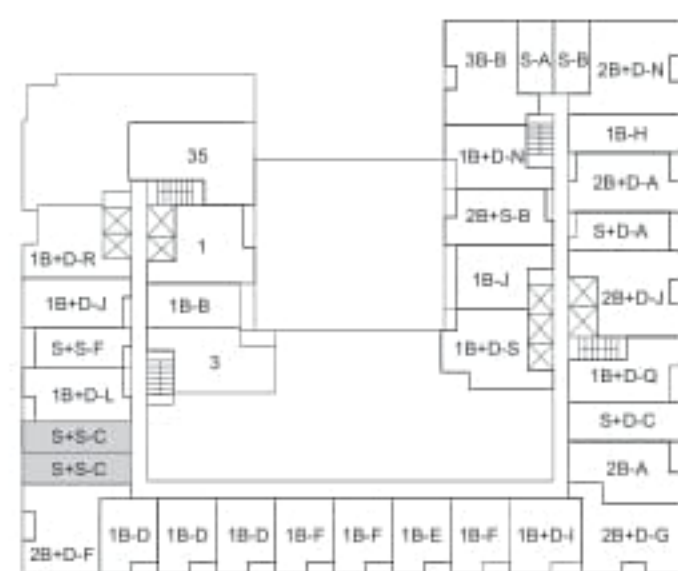
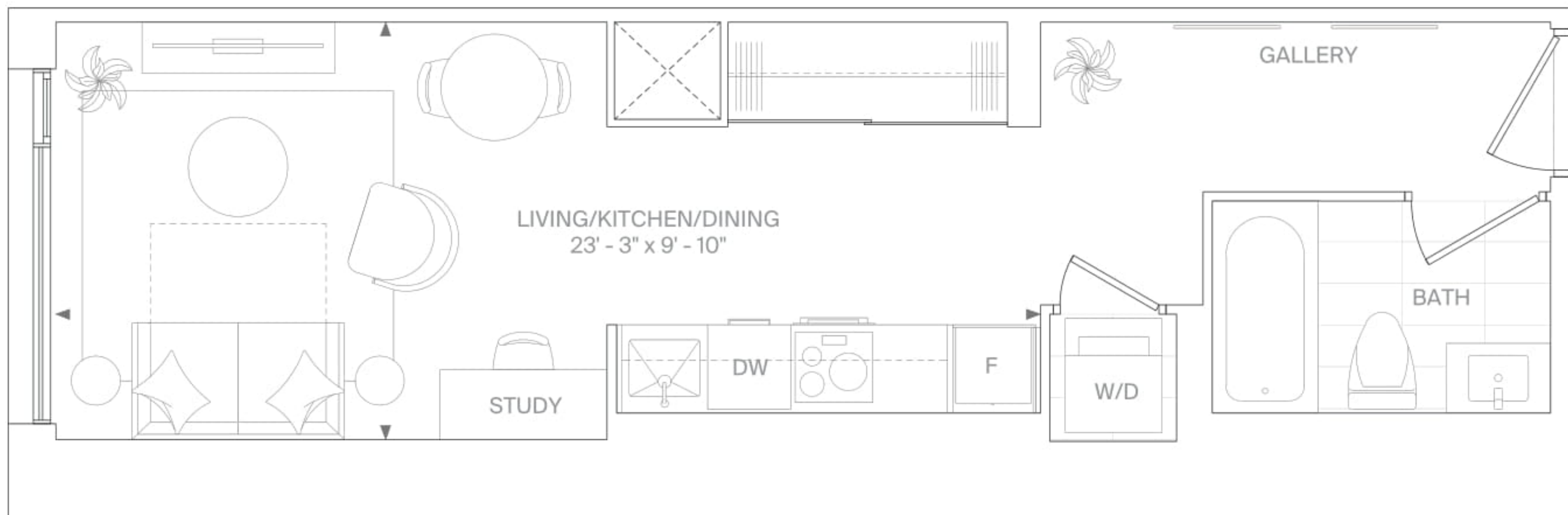

PODIUM LEVEL 2

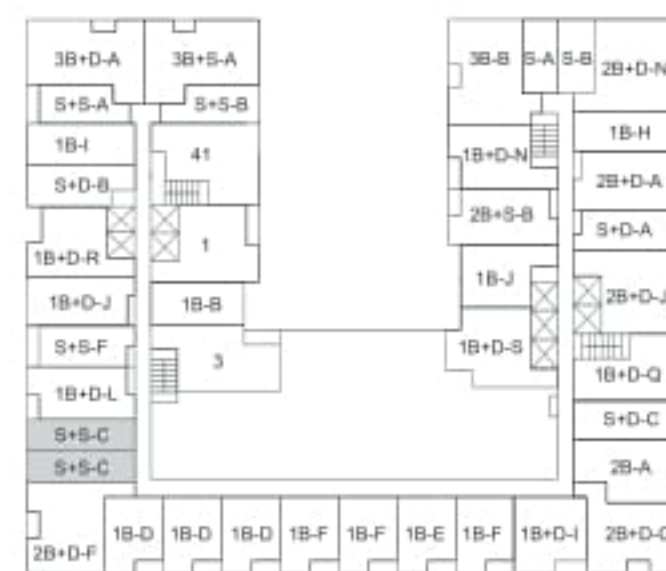

PODIUM LEVEL 3 - 5



ALL DIMENSIONS AND SPECIFICATIONS ARE APPROXIMATE. CERTAIN PLANS ARE REVERSE OR MIRROR IMAGE. BALCONY SQUARE FOOTAGES ARE ESTIMATED AND MAY VARY FROM THAT STATED. PLEASE SEE SALES REPRESENTATIVE FOR DETAILS. FURNITURE NOT INCLUDED. REFER TO KEY PLAN FOR UNIT LOCATION AND ORIENTATION. PREPARED JUNE 9, 2022

Canderel



RAD MARKETING
Sales & Marketing Consultant

S+S-D

INTERIOR 415 SF
STUDIO+STUDY, 1 BATH

FORÊT™

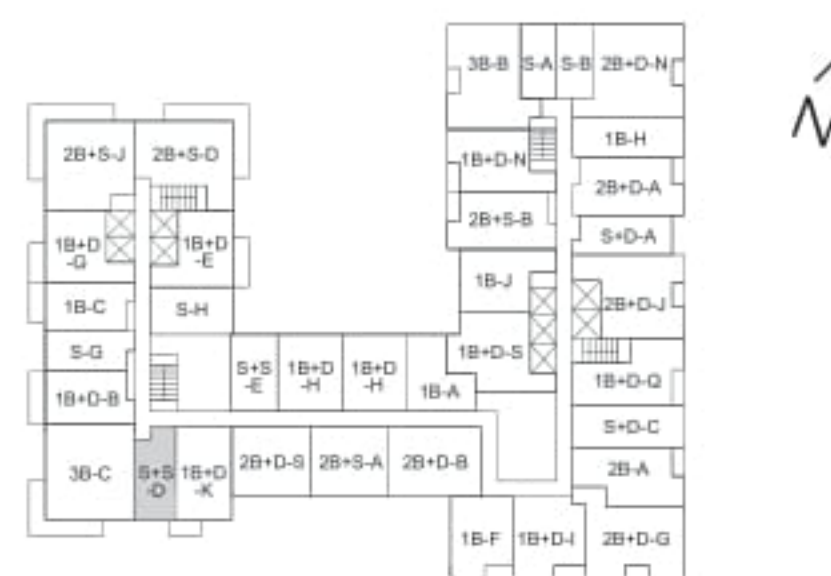
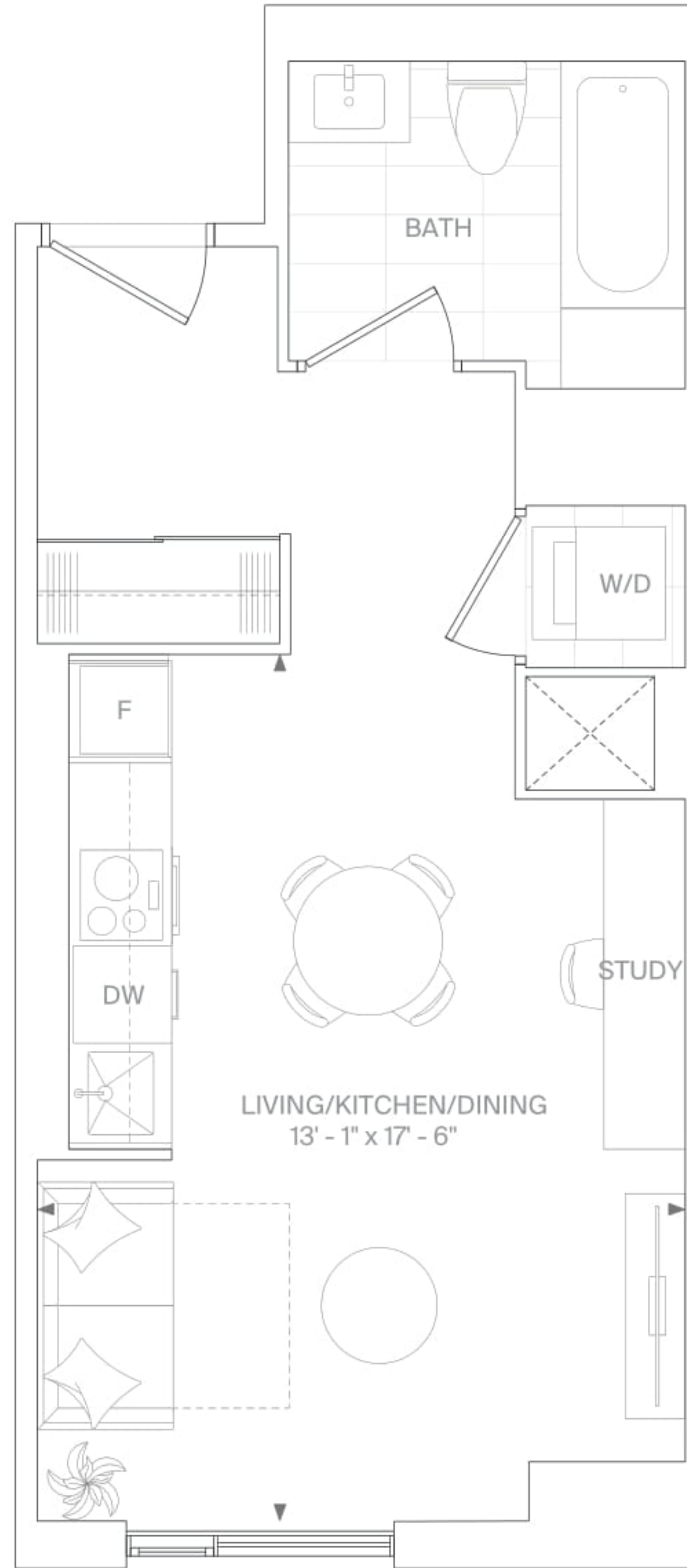
FOREST HILL



PODIUM LEVEL 8

ALL DIMENSIONS AND SPECIFICATIONS ARE APPROXIMATE. CERTAIN PLANS ARE REVERSE OR MIRROR IMAGE. BALCONY SQUARE FOOTAGES ARE ESTIMATED AND MAY VARY FROM THAT STATED. PLEASE SEE SALES REPRESENTATIVE FOR DETAILS. FURNITURE NOT INCLUDED. REFER TO KEY PLAN FOR UNIT LOCATION AND ORIENTATION. PREPARED JUNE 9, 2022

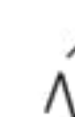
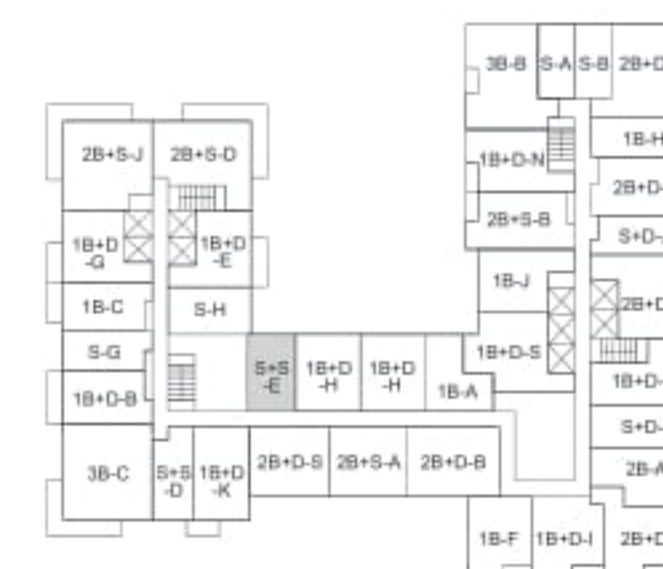
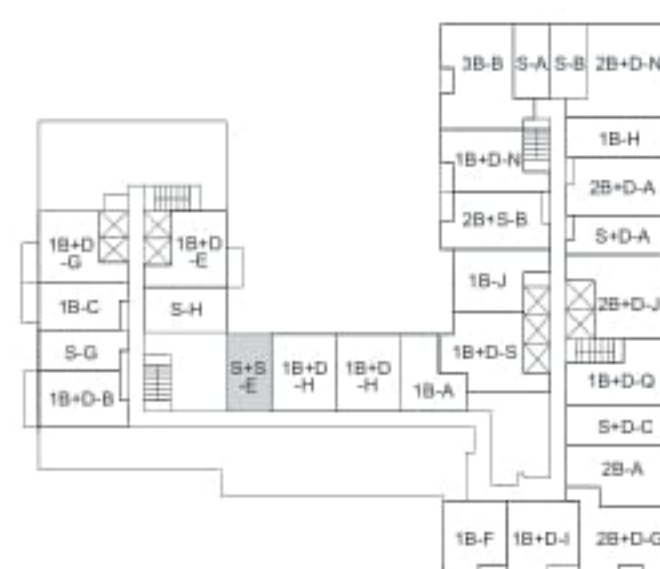
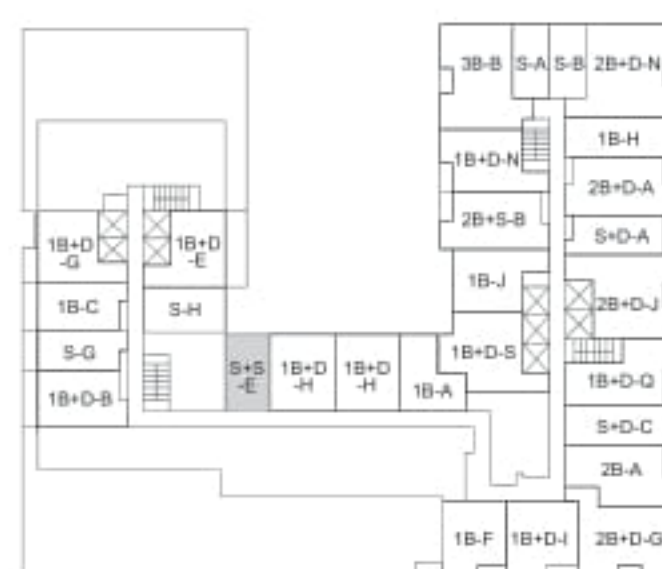
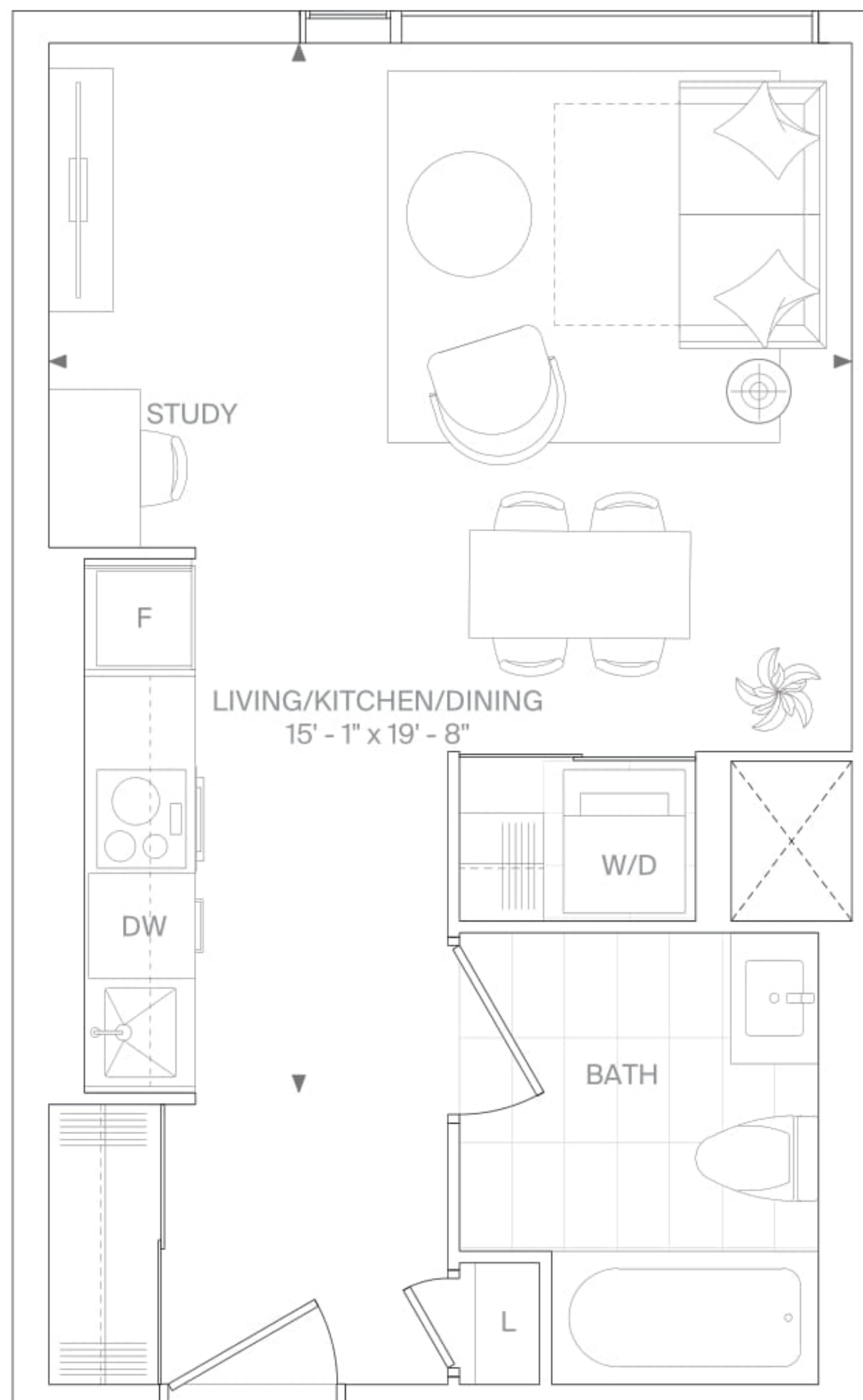

S+S-F

INTERIOR 433 SF | EXTERIOR 44 SF
STUDIO+STUDY, 1 BATH

FORÊT™

FOREST HILL

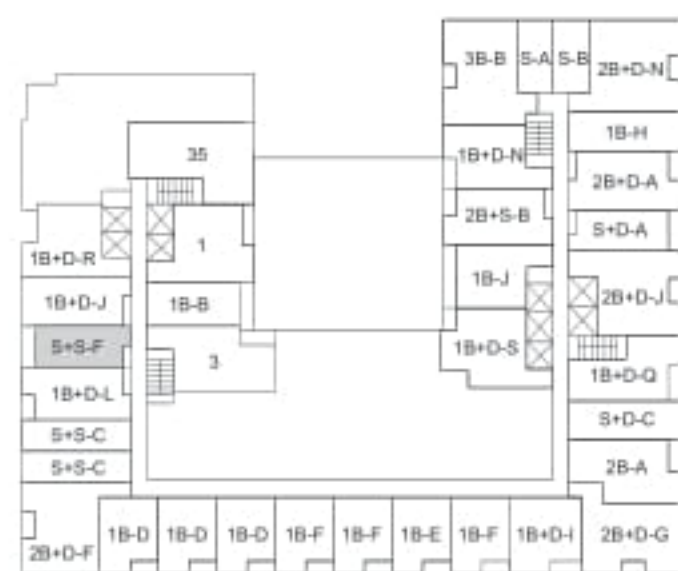
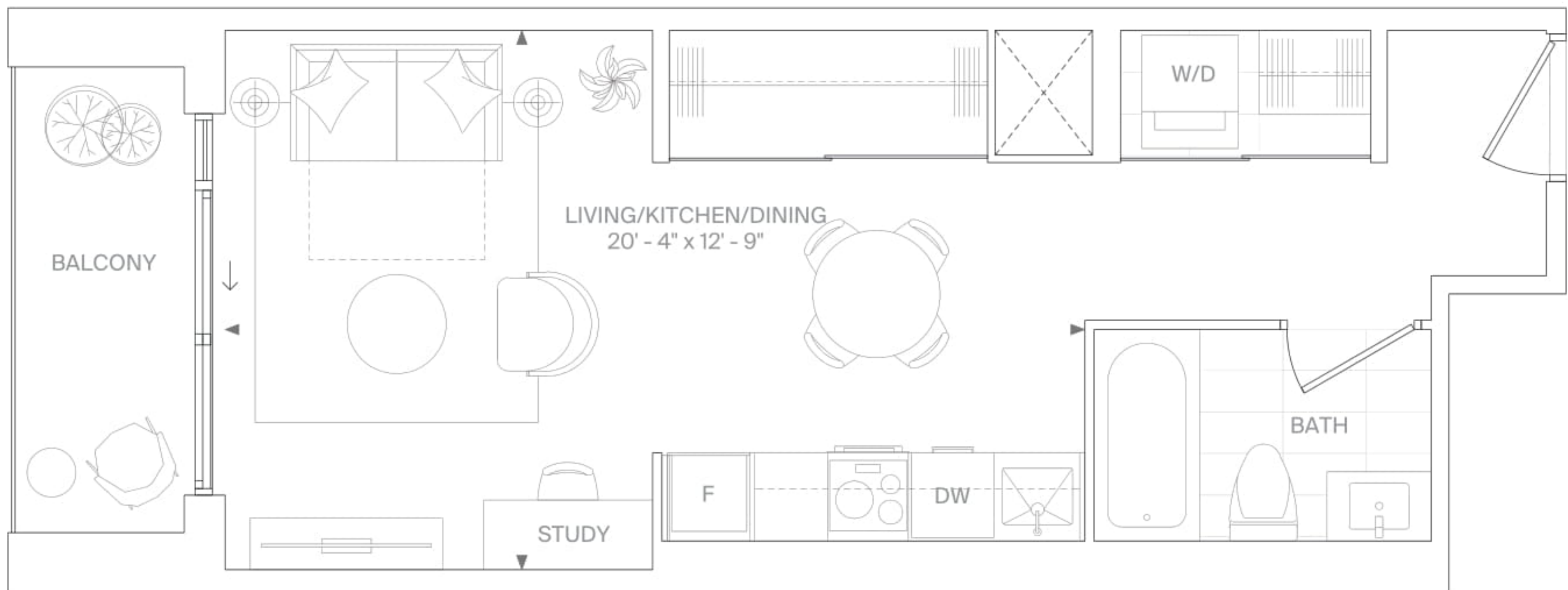

PODIUM LEVEL 2

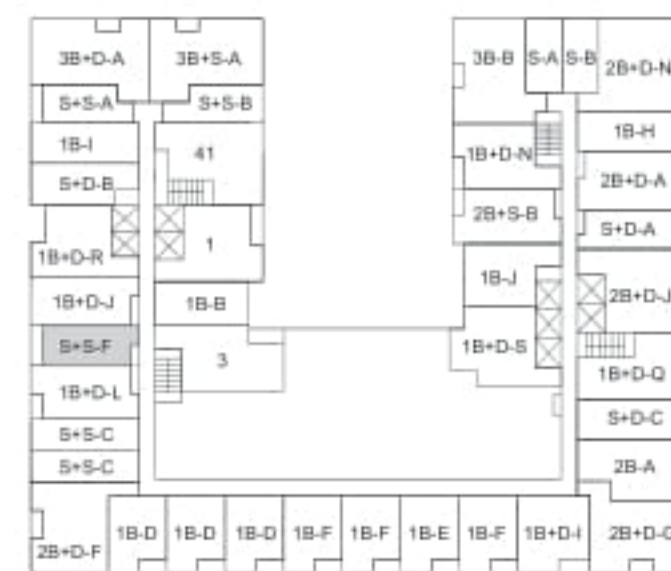

PODIUM LEVEL 3 - 5

ALL DIMENSIONS AND SPECIFICATIONS ARE APPROXIMATE. CERTAIN PLANS ARE REVERSE OR MIRROR IMAGE. BALCONY SQUARE FOOTAGES ARE ESTIMATED AND MAY VARY FROM THAT STATED. PLEASE SEE SALES REPRESENTATIVE FOR DETAILS. FURNITURE NOT INCLUDED. REFER TO KEY PLAN FOR UNIT LOCATION AND ORIENTATION. PREPARED JUNE 9, 2022

S+D-B

INTERIOR 475 SF
STUDIO+DEN, 1 BATH

FORÊT™

FOREST HILL

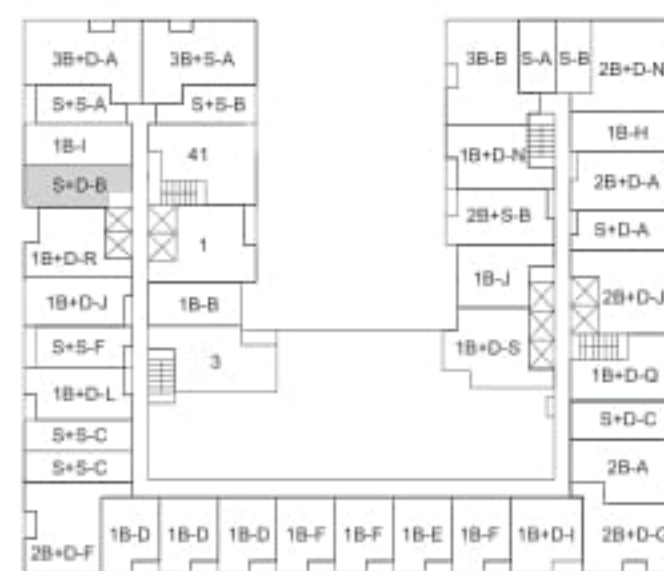
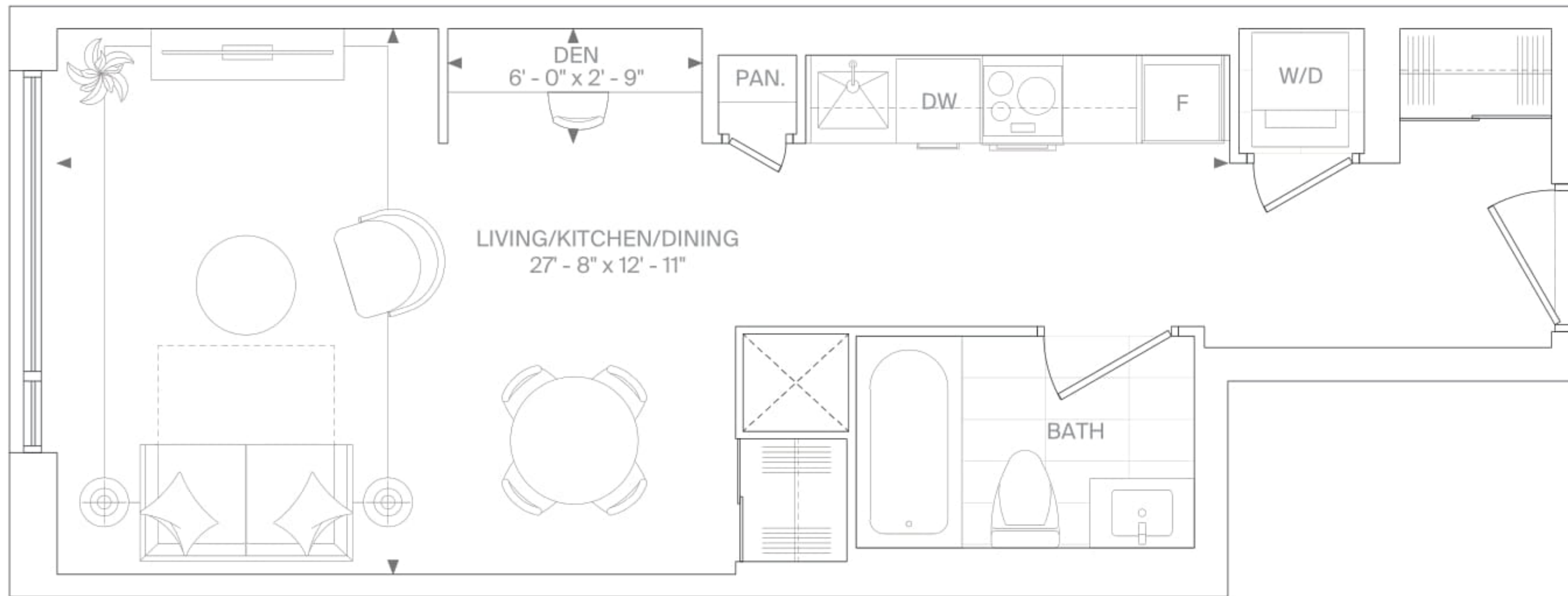

PODIUM LEVEL 3 - 5

ALL DIMENSIONS AND SPECIFICATIONS ARE APPROXIMATE. CERTAIN PLANS ARE REVERSE OR MIRROR IMAGE. BALCONY SQUARE FOOTAGES ARE ESTIMATED AND MAY VARY FROM THAT STATED. PLEASE SEE SALES REPRESENTATIVE FOR DETAILS. FURNITURE NOT INCLUDED. REFER TO KEY PLAN FOR UNIT LOCATION AND ORIENTATION. PREPARED JUNE 9, 2022

1B-B

INTERIOR 470 SF
1 BEDROOM, 1 BATH

FORÊT™

FOREST HILL

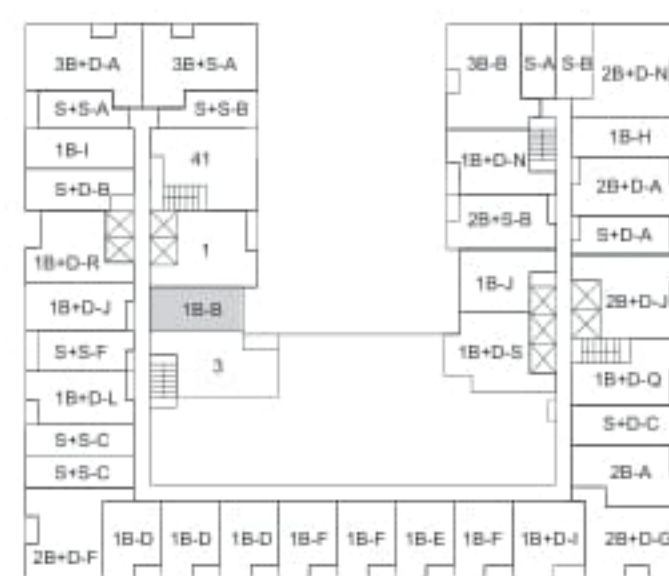
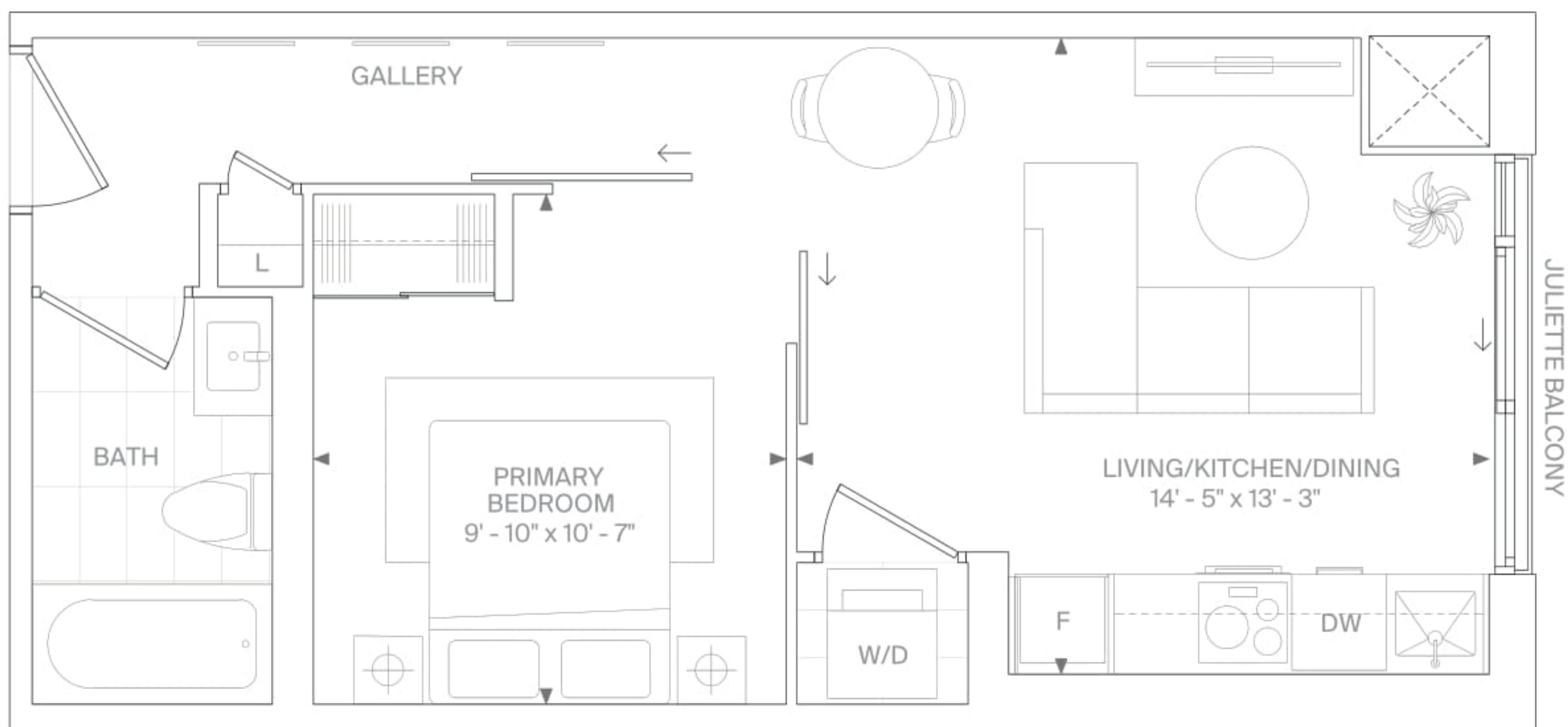

PODIUM LEVEL 4 - 5

ALL DIMENSIONS AND SPECIFICATIONS ARE APPROXIMATE. CERTAIN PLANS ARE REVERSE OR MIRROR IMAGE. BALCONY SQUARE FOOTAGES ARE ESTIMATED AND MAY VARY FROM THAT STATED. PLEASE SEE SALES REPRESENTATIVE FOR DETAILS. FURNITURE NOT INCLUDED. REFER TO KEY PLAN FOR UNIT LOCATION AND ORIENTATION. PREPARED JUNE 9, 2022

1B-C

INTERIOR 482 SF | EXTERIOR 71 SF
1 BEDROOM, 1 BATH

FORÊT™

FOREST HILL

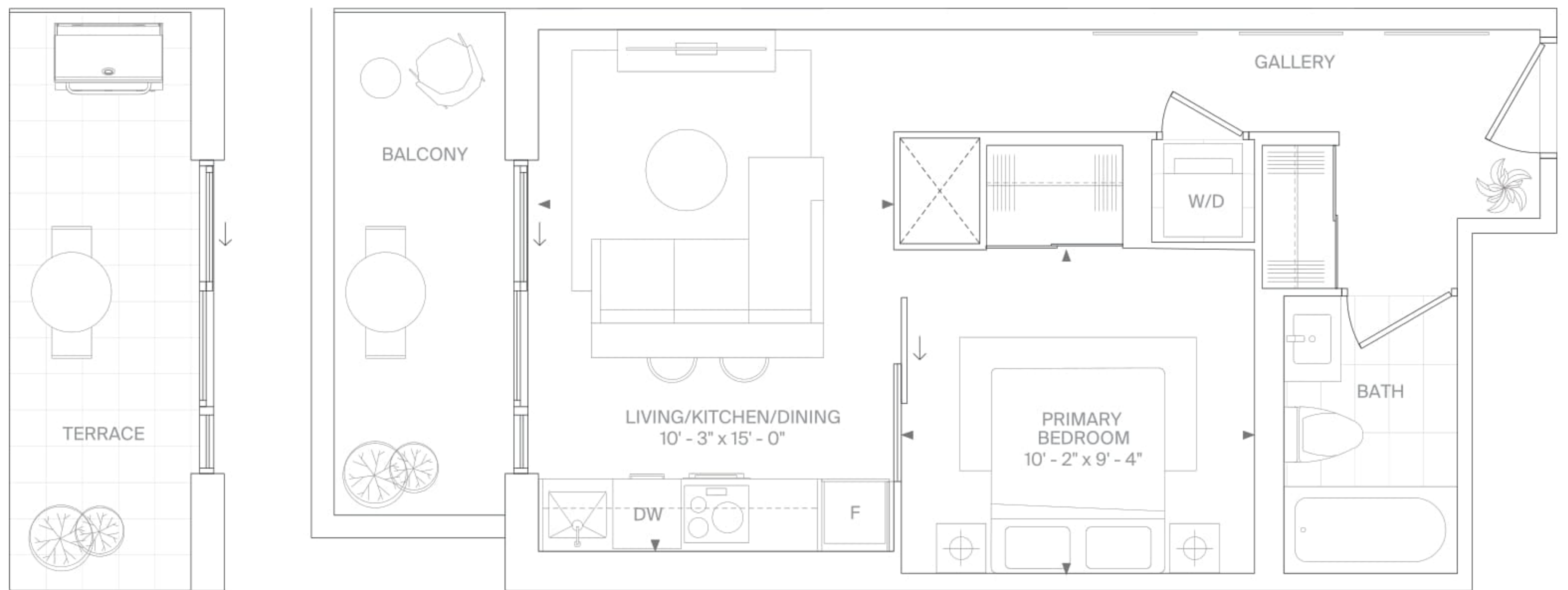

LEVEL 6 EXTERIOR 88 SF

LEVEL 7-29 EXTERIOR 71 SF

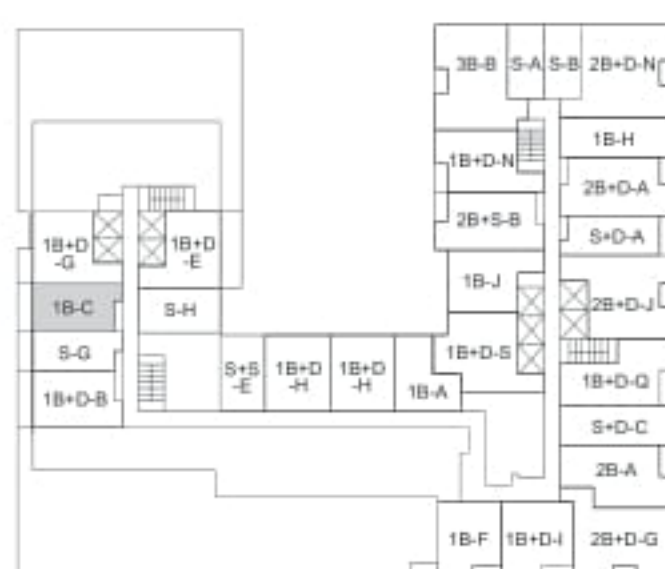

PODIUM LEVEL 6

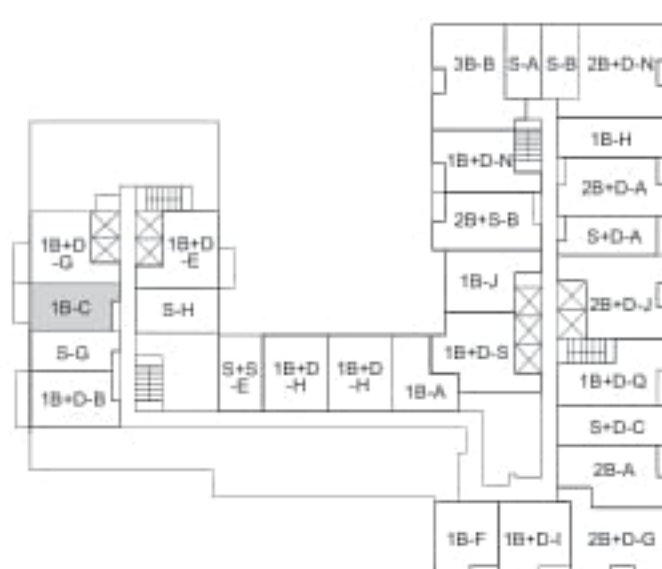

PODIUM LEVEL 7

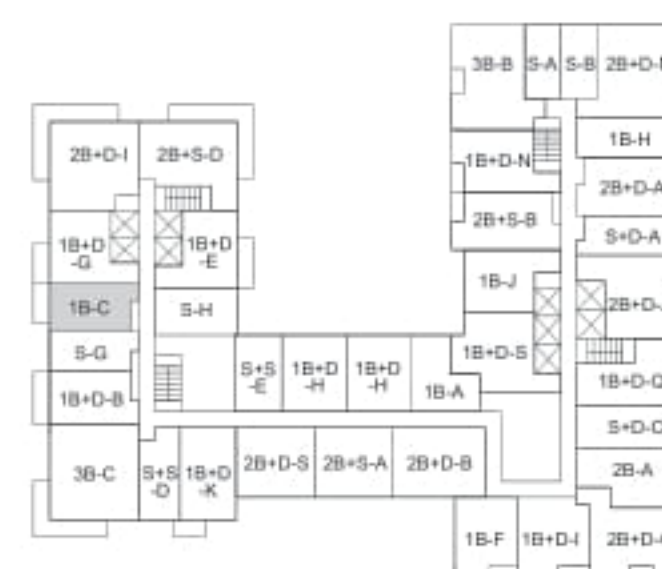

PODIUM LEVEL 8

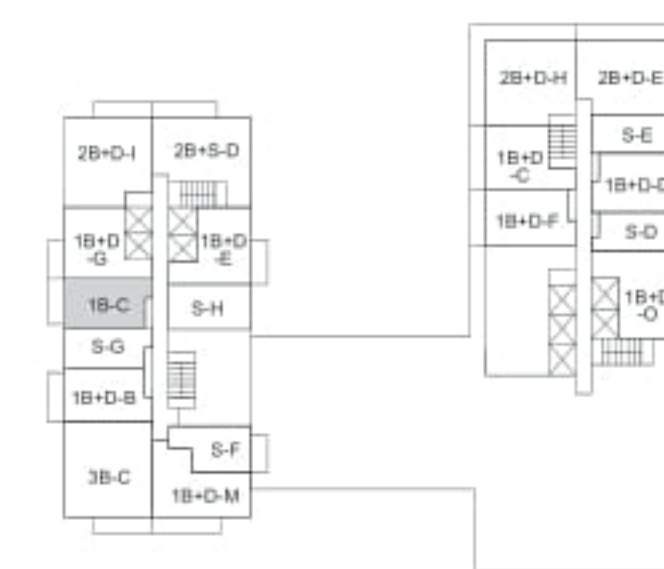

PODIUM LEVEL 9

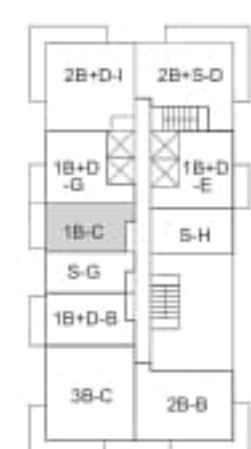

TOWER 2 LEVEL 10

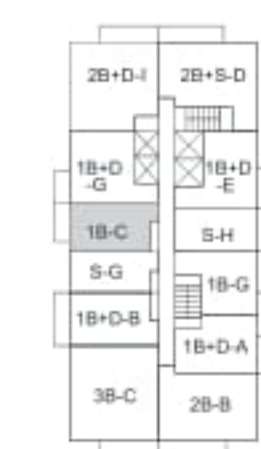

TOWER 2 LEVEL 11



TOWER 2 LEVEL 12 - 29

ALL DIMENSIONS AND SPECIFICATIONS ARE APPROXIMATE. CERTAIN PLANS ARE REVERSE OR MIRROR IMAGE. BALCONY SQUARE FOOTAGES ARE ESTIMATED AND MAY VARY FROM THAT STATED. PLEASE SEE SALES REPRESENTATIVE FOR DETAILS. FURNITURE NOT INCLUDED. REFER TO KEY PLAN FOR UNIT LOCATION AND ORIENTATION. PREPARED JUNE 9, 2022

1B-D

INTERIOR 473 SF | EXTERIOR 34 SF
1 BEDROOM, 1 BATH

FORÊT™

FOREST HILL

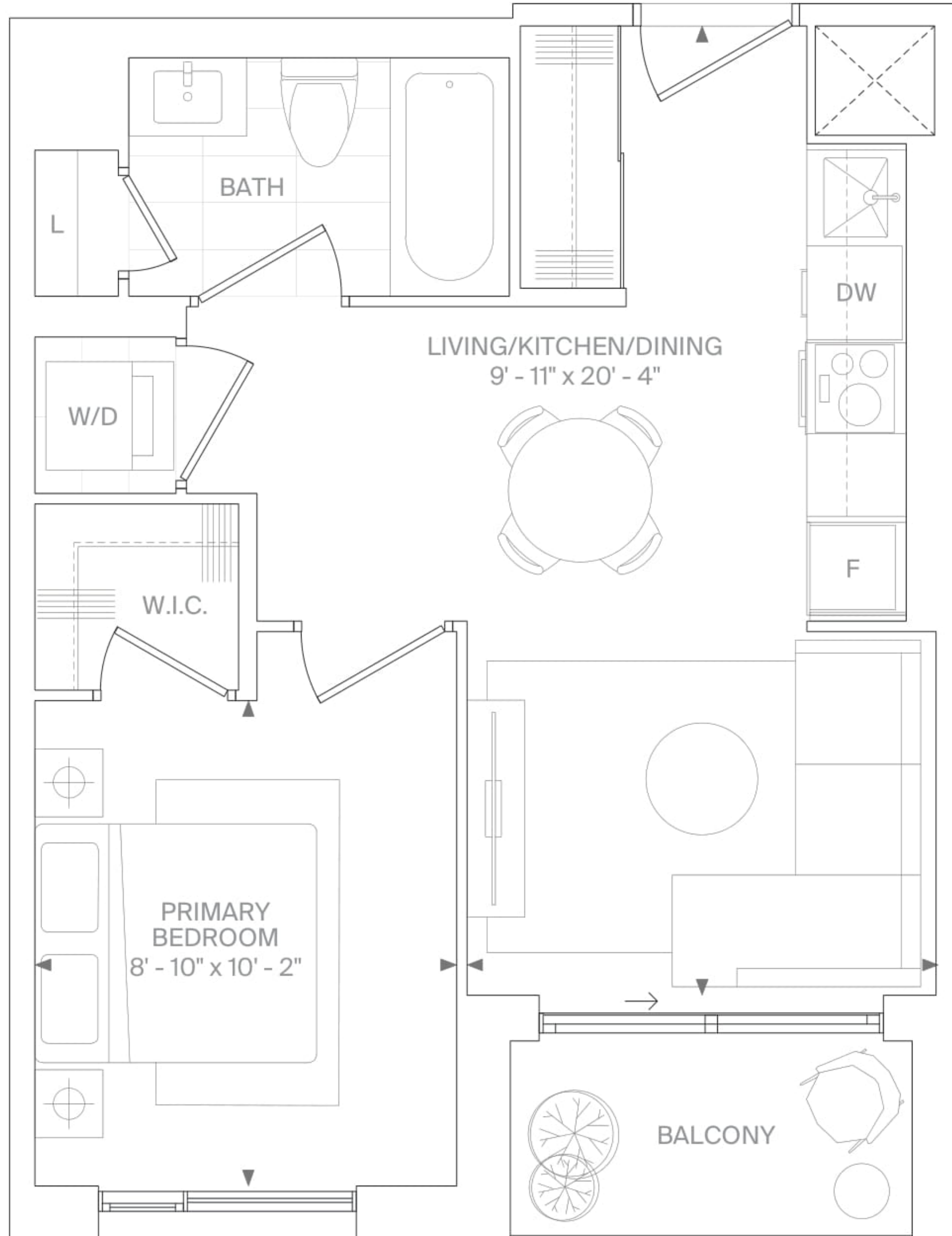

UNIT 25 INTERIOR 476 SF | UNIT 26, 27 INTERIOR 483 SF

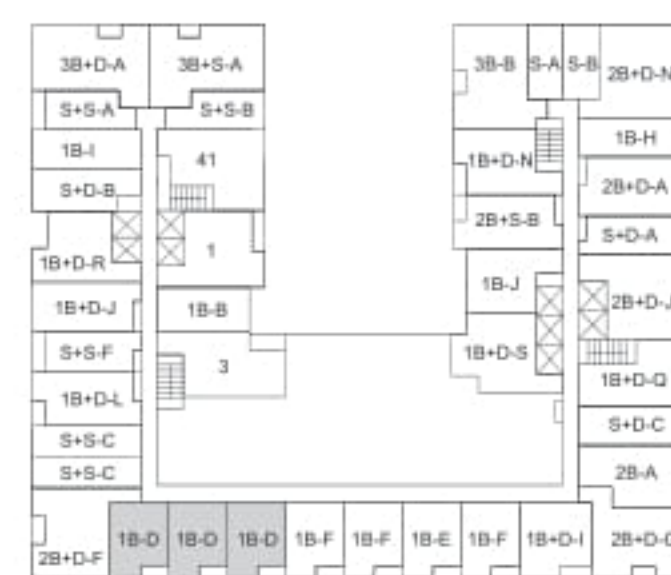
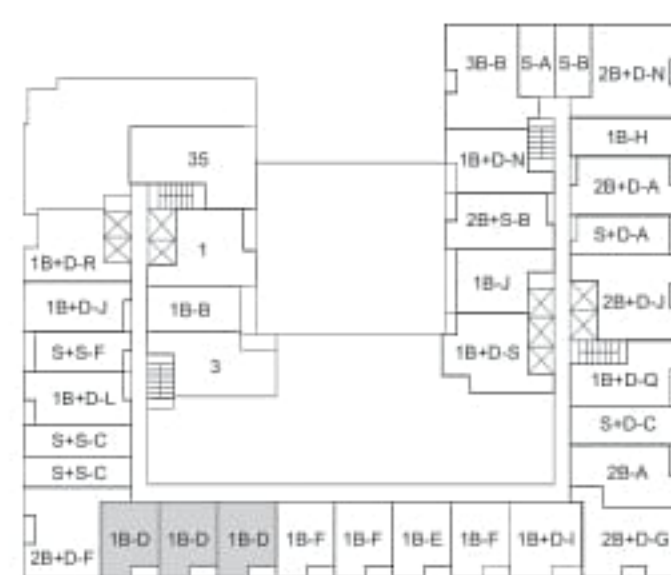

ALL DIMENSIONS AND SPECIFICATIONS ARE APPROXIMATE. CERTAIN PLANS ARE REVERSE OR MIRROR IMAGE. BALCONY SQUARE FOOTAGES ARE ESTIMATED AND MAY VARY FROM THAT STATED. PLEASE SEE SALES REPRESENTATIVE FOR DETAILS. FURNITURE NOT INCLUDED. REFER TO KEY PLAN FOR UNIT LOCATION AND ORIENTATION. PREPARED JUNE 9, 2022

1B-F

INTERIOR 479 SF | EXTERIOR 34 SF
1 BEDROOM, 1 BATH

FORÊT™

FOREST HILL

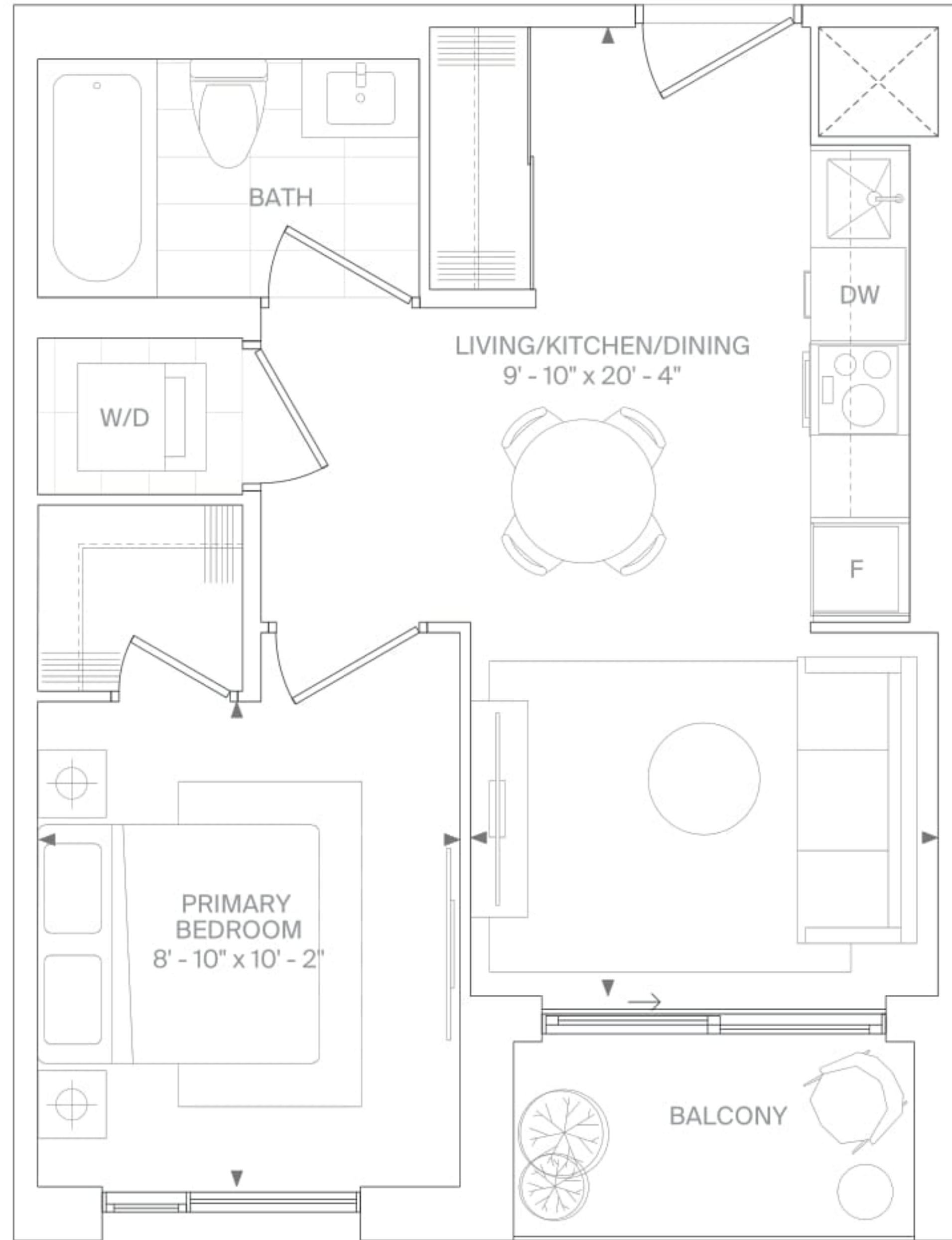

LEVEL 6, 7, 8 INTERIOR 504 SF

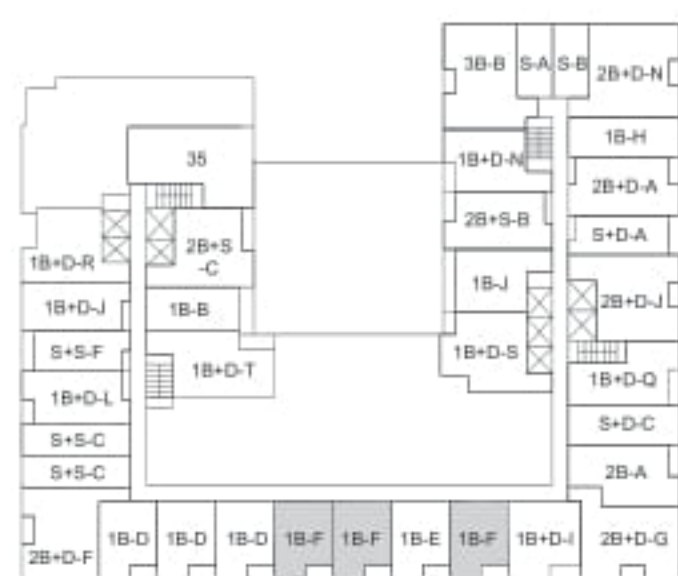

PODIUM LEVEL 2

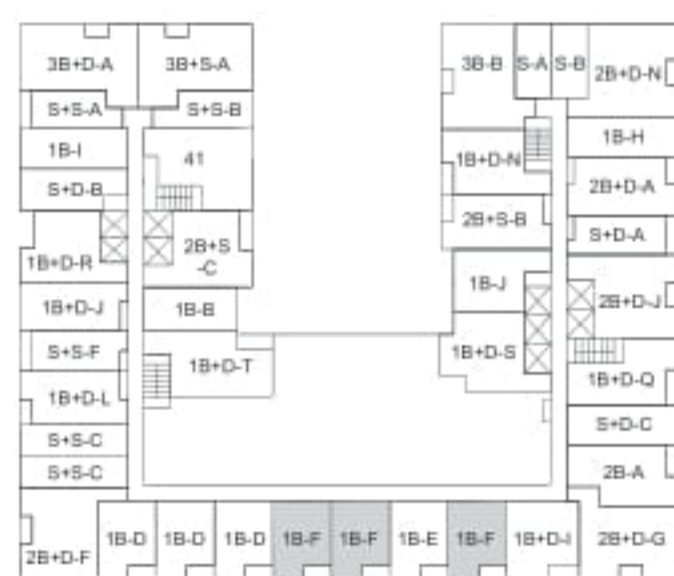

PODIUM LEVEL 3 - 5

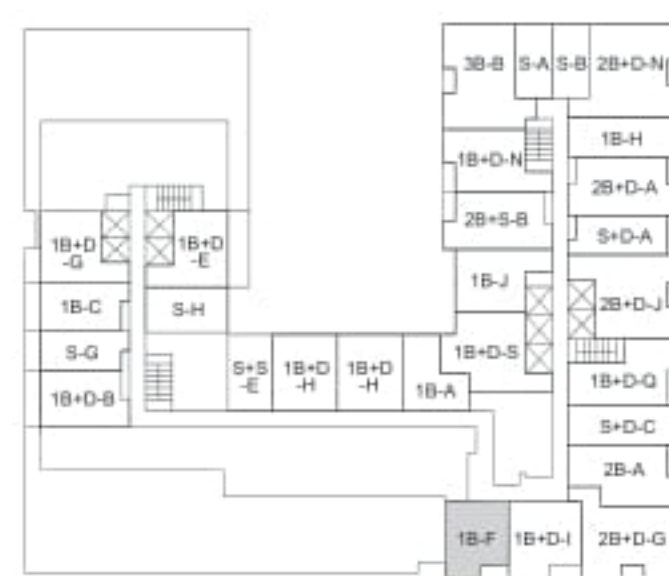

PODIUM LEVEL 6

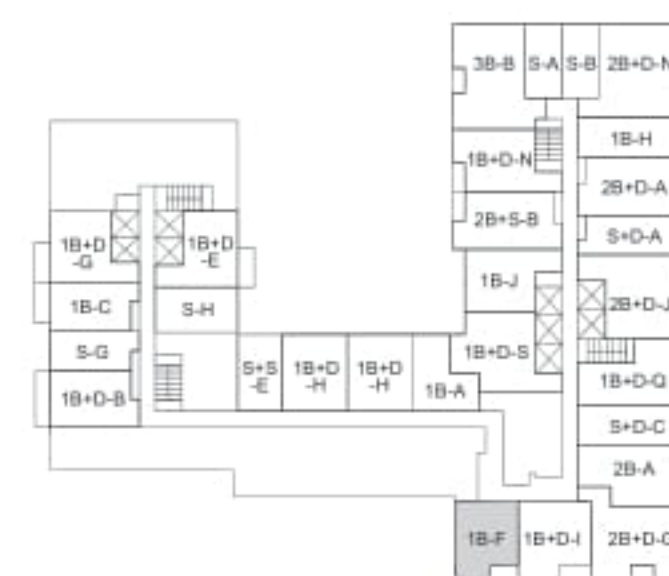

PODIUM LEVEL 7

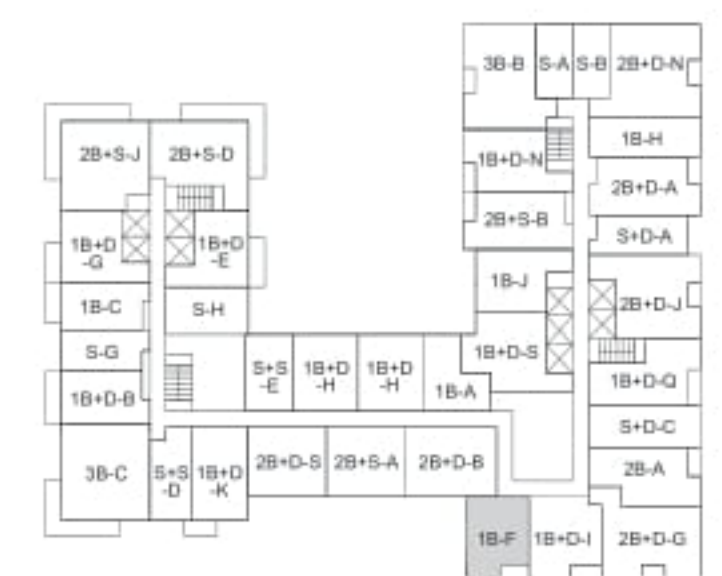

PODIUM LEVEL 8

ALL DIMENSIONS AND SPECIFICATIONS ARE APPROXIMATE. CERTAIN PLANS ARE REVERSE OR MIRROR IMAGE. BALCONY SQUARE FOOTAGES ARE ESTIMATED AND MAY VARY FROM THAT STATED. PLEASE SEE SALES REPRESENTATIVE FOR DETAILS. FURNITURE NOT INCLUDED. REFER TO KEY PLAN FOR UNIT LOCATION AND ORIENTATION. PREPARED JUNE 9, 2022

1B-G

INTERIOR 489 SF | EXTERIOR 57 SF
1 BEDROOM, 1 BATH

FORÊT™

FOREST HILL

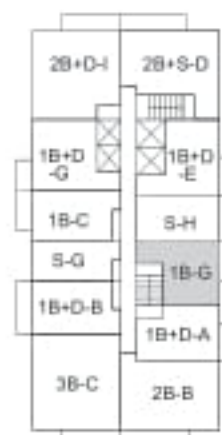
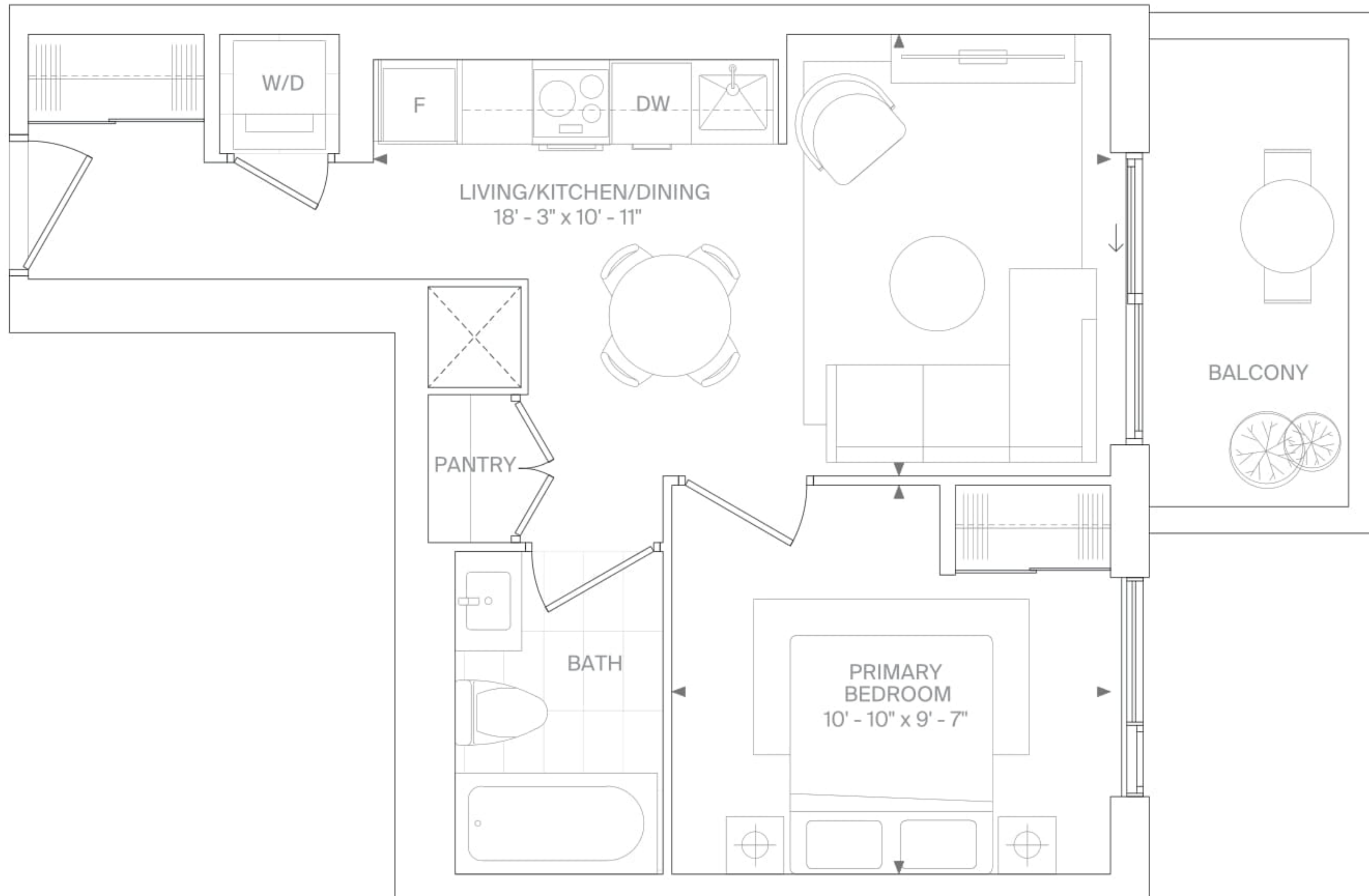

TOWER 2 LEVEL 11



TOWER 2 LEVEL 12 - 29



ALL DIMENSIONS AND SPECIFICATIONS ARE APPROXIMATE. CERTAIN PLANS ARE REVERSE OR MIRROR IMAGE. BALCONY SQUARE FOOTAGES ARE ESTIMATED AND MAY VARY FROM THAT STATED. PLEASE SEE SALES REPRESENTATIVE FOR DETAILS. FURNITURE NOT INCLUDED. REFER TO KEY PLAN FOR UNIT LOCATION AND ORIENTATION. PREPARED JUNE 9, 2022

1B-I

INTERIOR 521 SF
1 BEDROOM, 1 BATH

FORÊT™

FOREST HILL

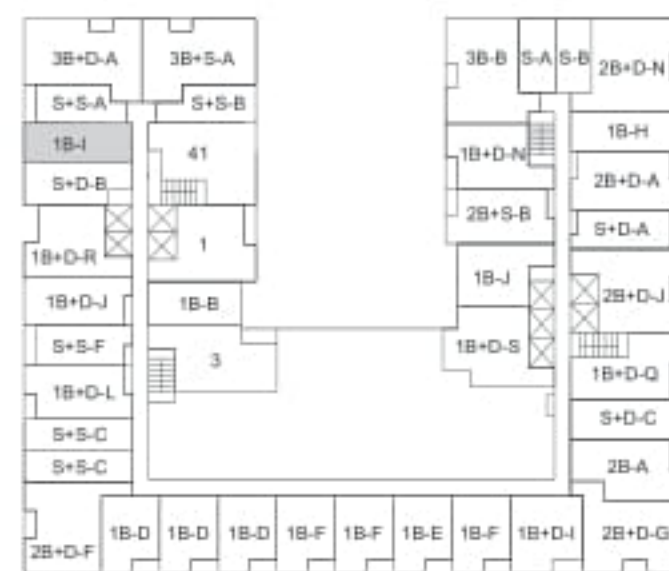
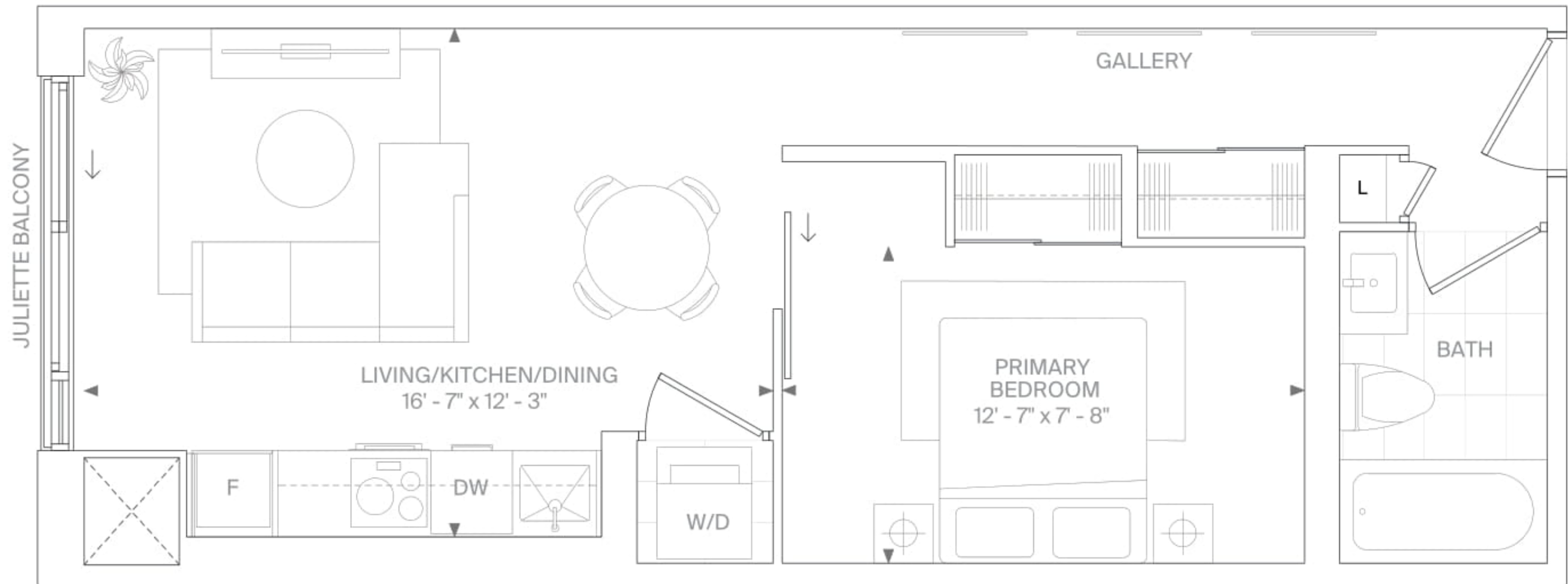

PODIUM LEVEL 3 - 5

ALL DIMENSIONS AND SPECIFICATIONS ARE APPROXIMATE. CERTAIN PLANS ARE REVERSE OR MIRROR IMAGE. BALCONY SQUARE FOOTAGES ARE ESTIMATED AND MAY VARY FROM THAT STATED. PLEASE SEE SALES REPRESENTATIVE FOR DETAILS. FURNITURE NOT INCLUDED. REFER TO KEY PLAN FOR UNIT LOCATION AND ORIENTATION. PREPARED JUNE 9, 2022

1B+D-A

INTERIOR 501 SF | EXTERIOR 54 SF
1 BEDROOM+DEN, 1 BATH

FORÊT™

FOREST HILL

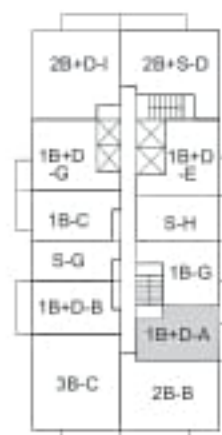
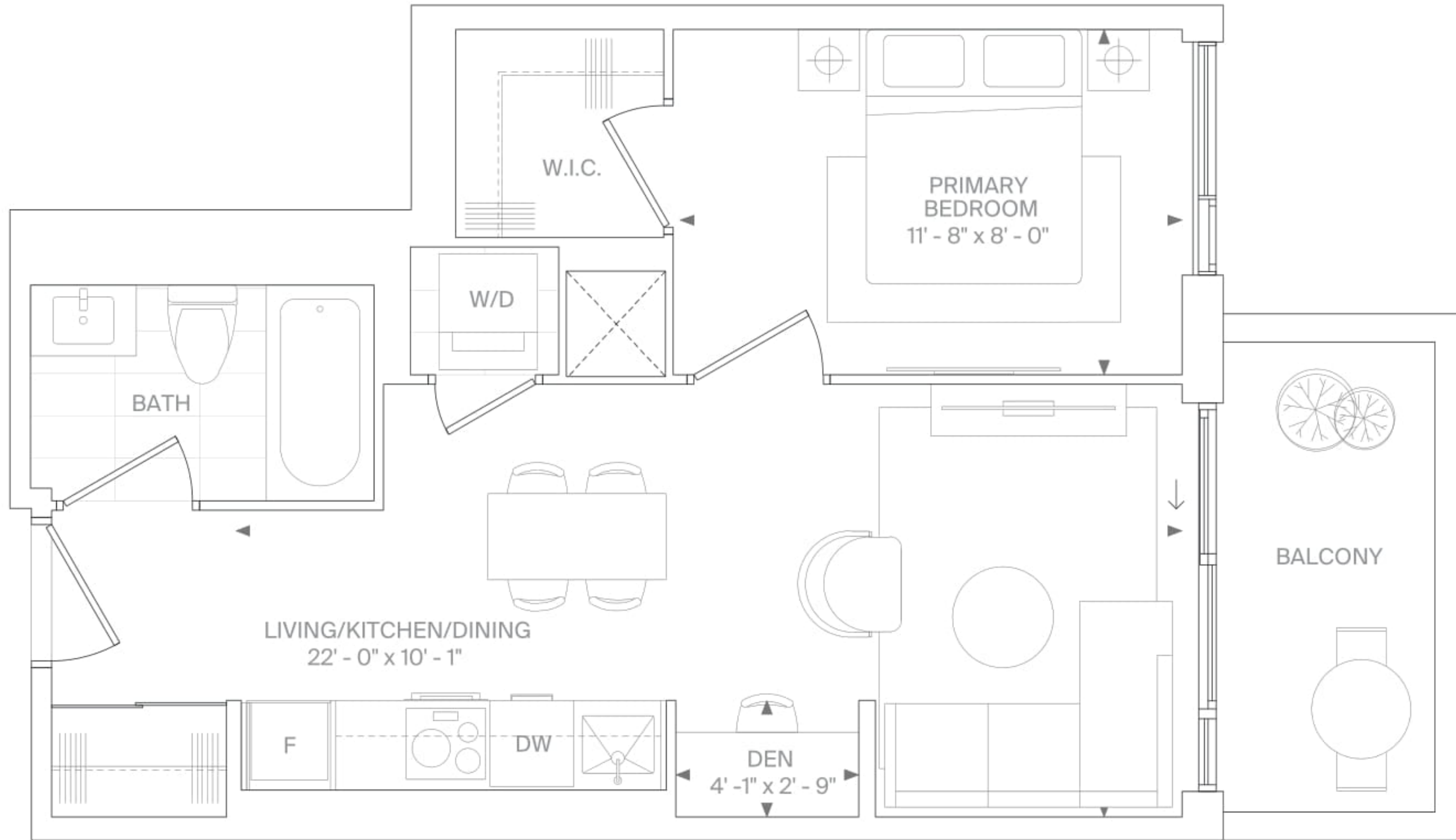

TOWER 2 LEVEL 11



TOWER 2 LEVEL 12 - 29



ALL DIMENSIONS AND SPECIFICATIONS ARE APPROXIMATE. CERTAIN PLANS ARE REVERSE OR MIRROR IMAGE. BALCONY SQUARE FOOTAGES ARE ESTIMATED AND MAY VARY FROM THAT STATED. PLEASE SEE SALES REPRESENTATIVE FOR DETAILS. FURNITURE NOT INCLUDED. REFER TO KEY PLAN FOR UNIT LOCATION AND ORIENTATION. PREPARED JUNE 9, 2022

1B+D-B

INTERIOR 525 SF | EXTERIOR 83 SF
1 BEDROOM+DEN, 1 BATH

FORÊT™

FOREST HILL

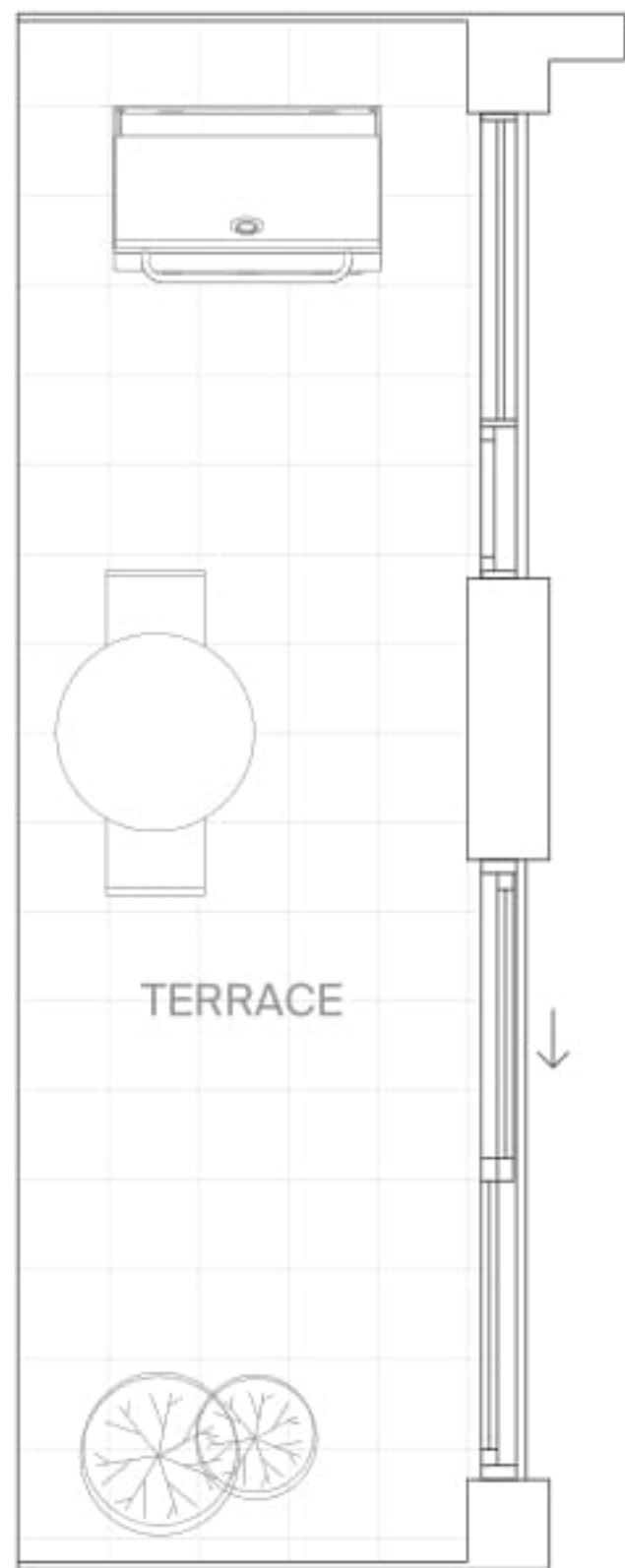

LEVEL 6 EXTERIOR 94 SF

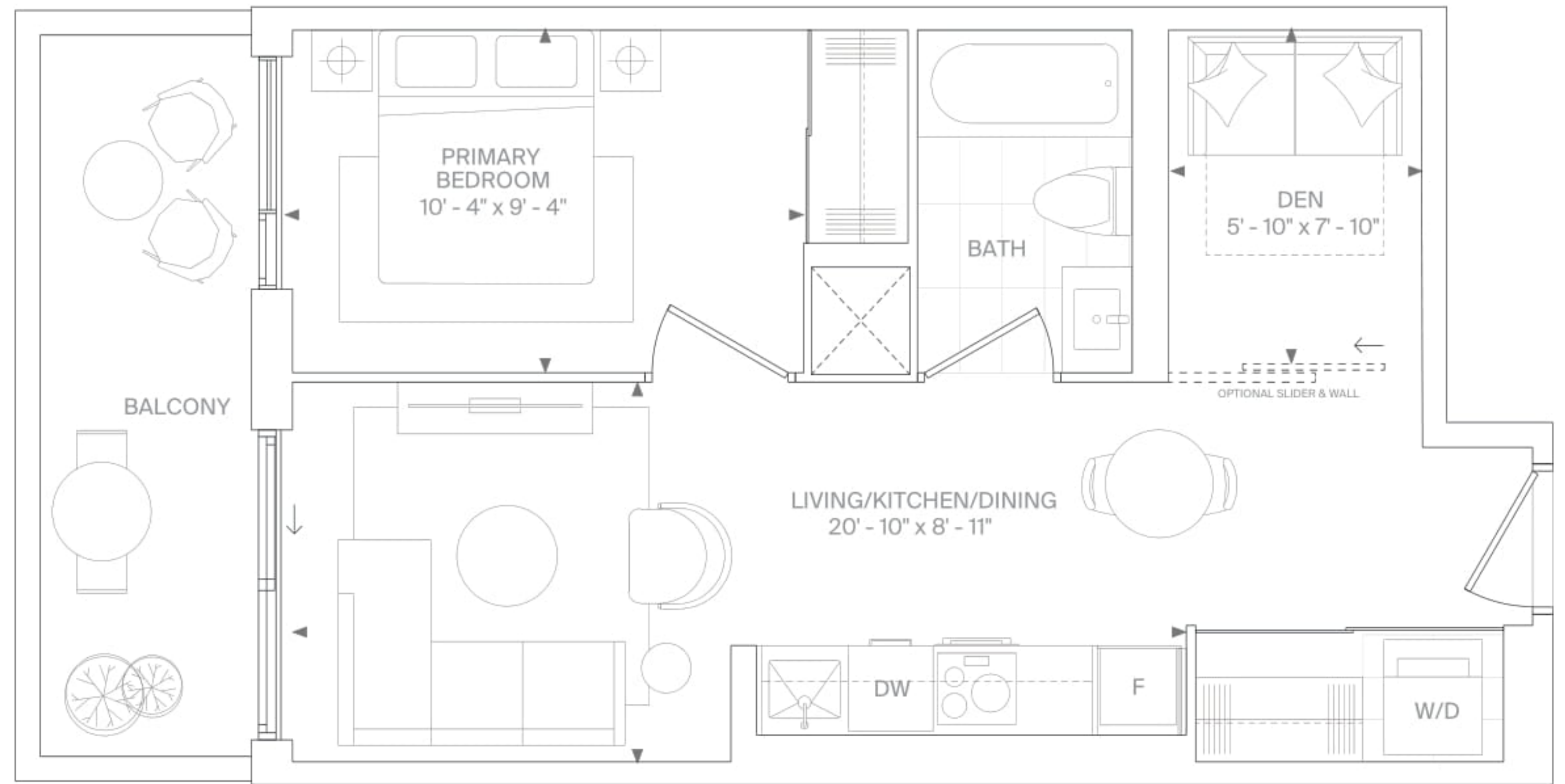

LEVEL 7-29 EXTERIOR 83 SF

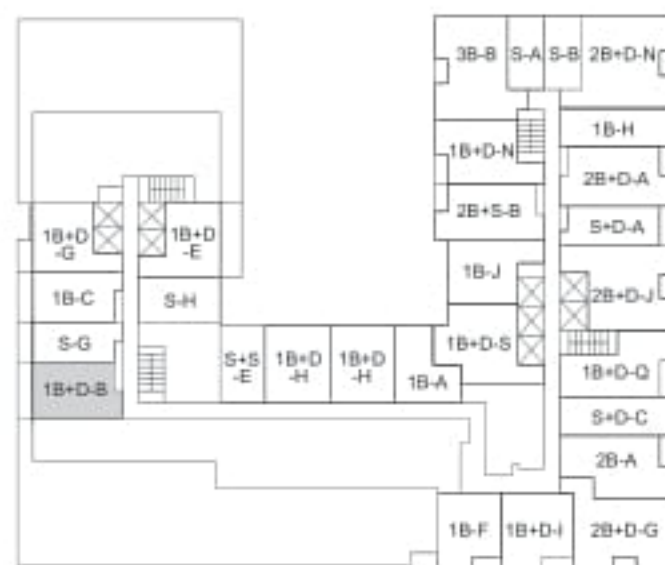

PODIUM LEVEL 6

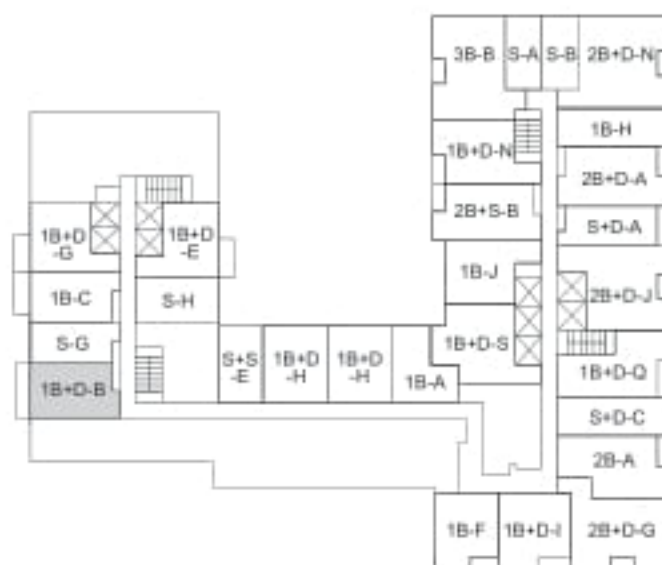

PODIUM LEVEL 7

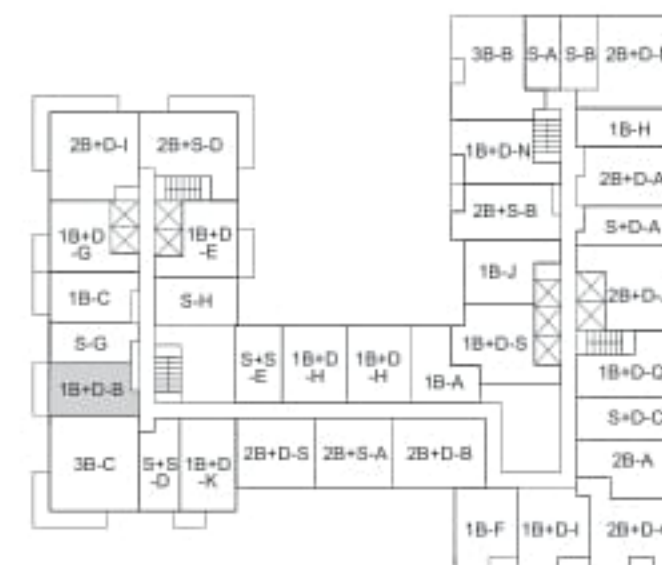

PODIUM LEVEL 8

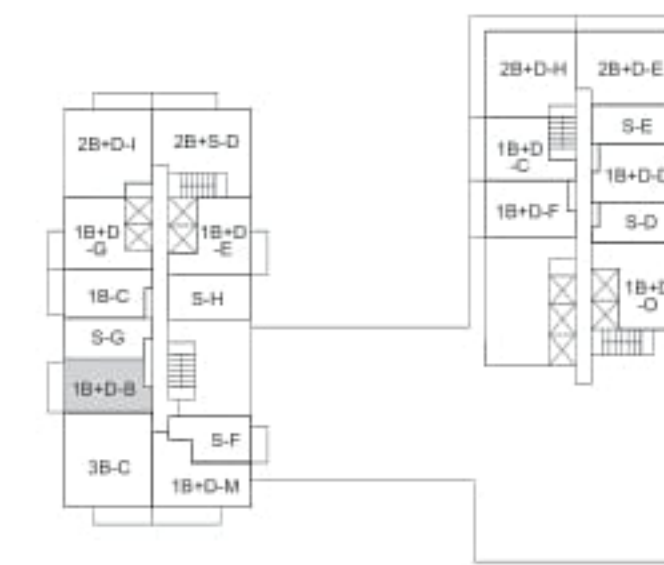

PODIUM LEVEL 9

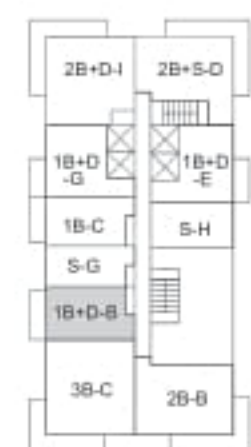

TOWER 2 LEVEL 10

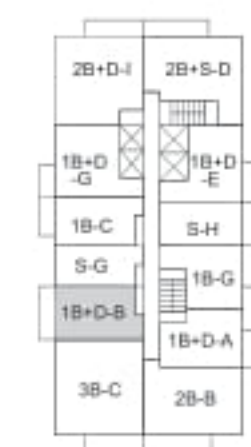

TOWER 2 LEVEL 11



TOWER 2 LEVEL 12 - 29

ALL DIMENSIONS AND SPECIFICATIONS ARE APPROXIMATE. CERTAIN PLANS ARE REVERSE OR MIRROR IMAGE. BALCONY SQUARE FOOTAGES ARE ESTIMATED AND MAY VARY FROM THAT STATED. PLEASE SEE SALES REPRESENTATIVE FOR DETAILS. FURNITURE NOT INCLUDED. REFER TO KEY PLAN FOR UNIT LOCATION AND ORIENTATION. PREPARED JUNE 9, 2022

1B+D-E

INTERIOR 563 SF | EXTERIOR 64 SF
1 BEDROOM+DEN, 1 BATH

FORÊT™

FOREST HILL

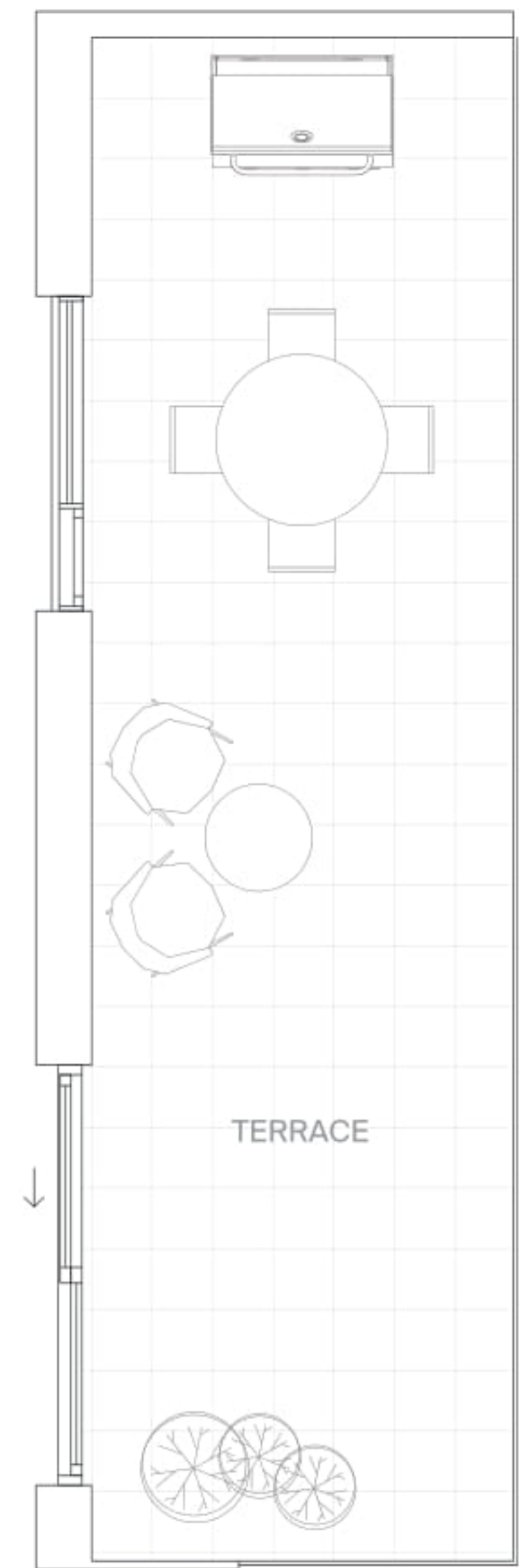
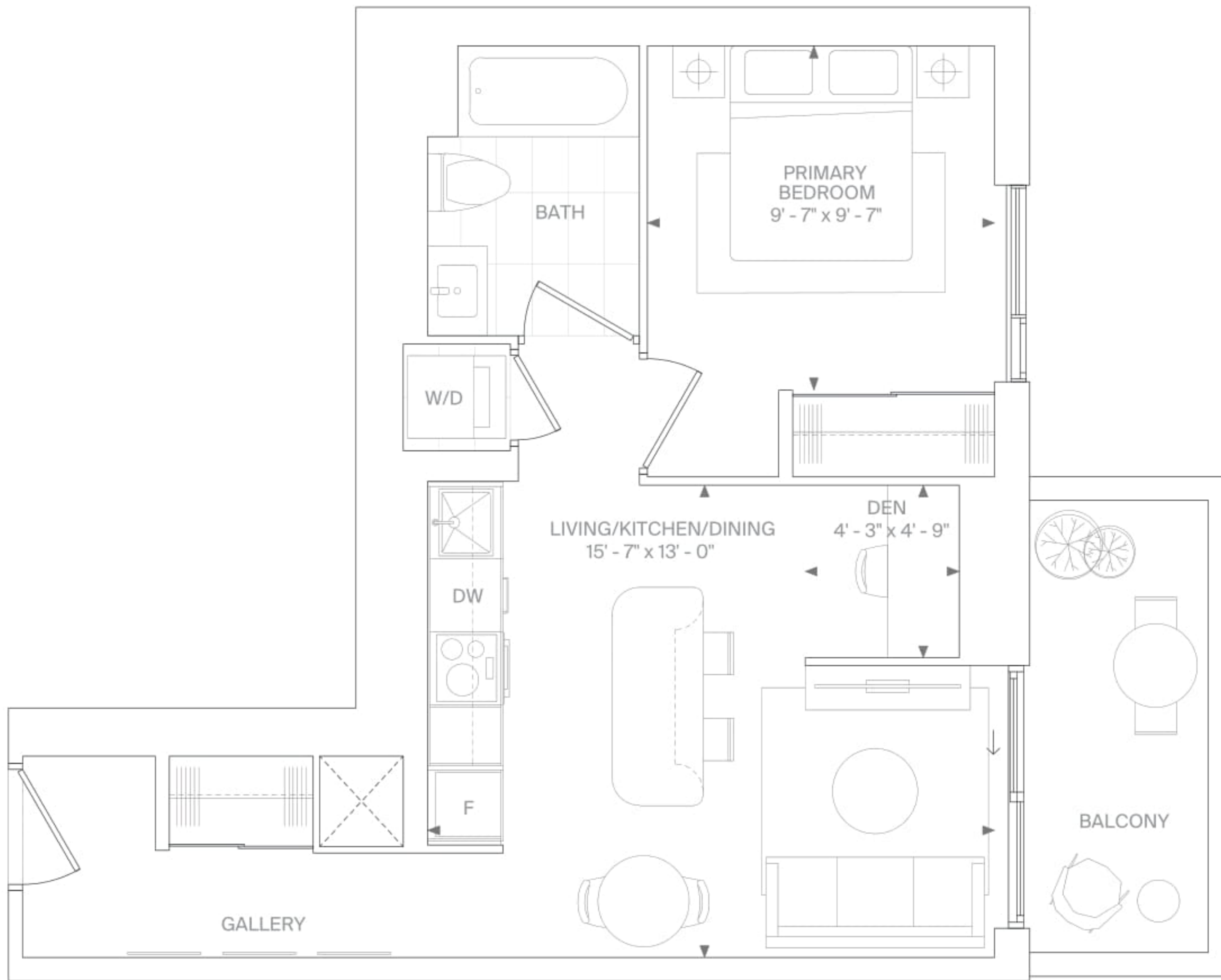

LEVEL 6 EXTERIOR 190 SF

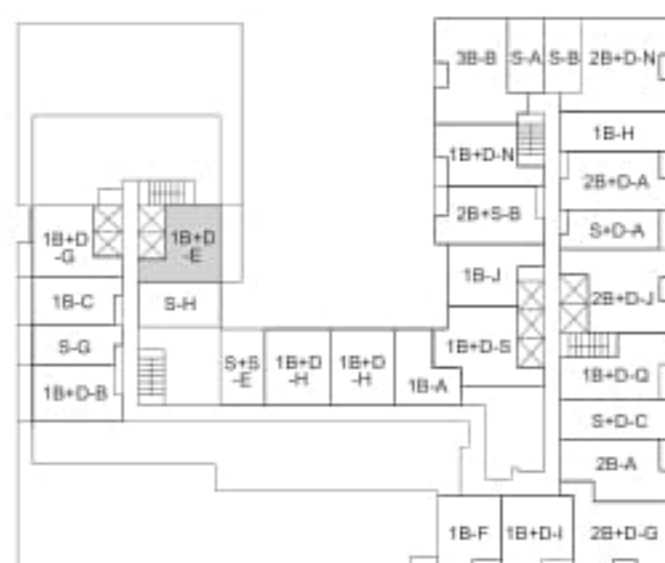

PODIUM LEVEL 6

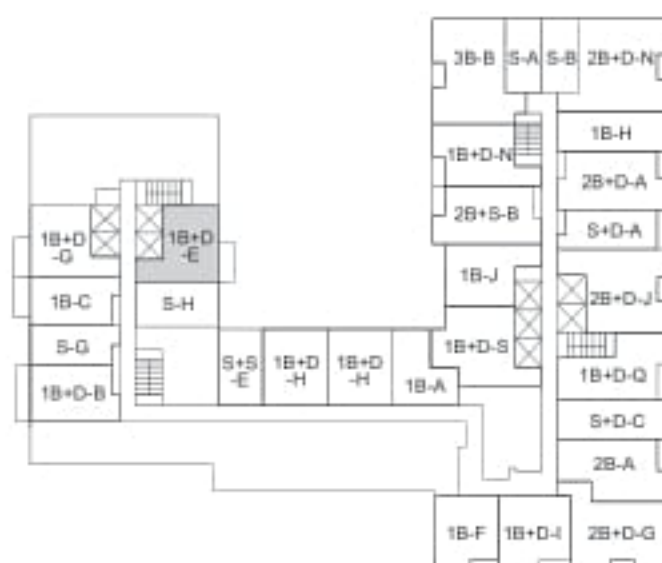

PODIUM LEVEL 7

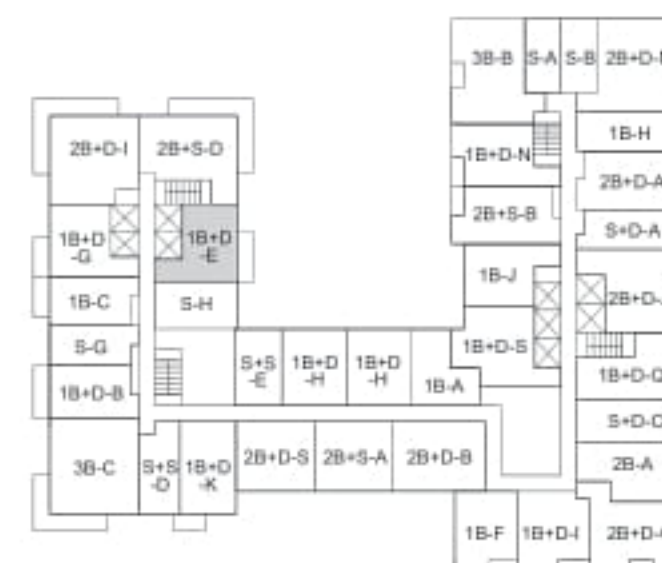

PODIUM LEVEL 8

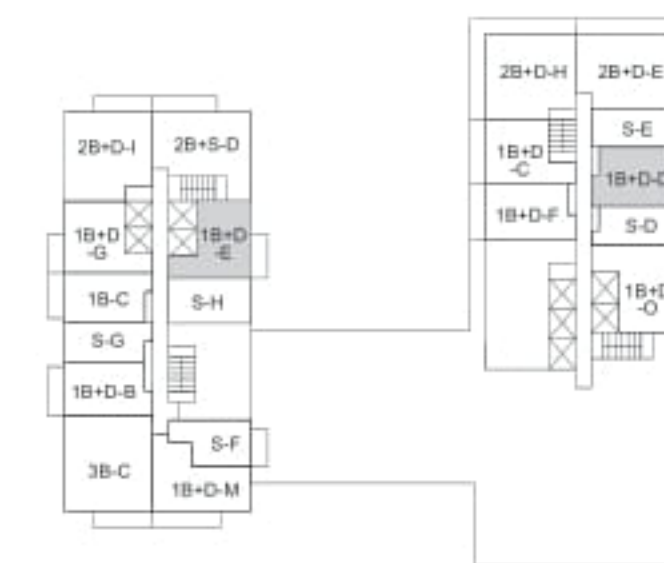

PODIUM LEVEL 9

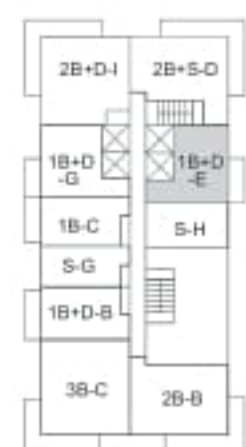

TOWER 2 LEVEL 10



TOWER 2 LEVEL 11



TOWER 2 LEVEL 12 - 29

ALL DIMENSIONS AND SPECIFICATIONS ARE APPROXIMATE. CERTAIN PLANS ARE REVERSE OR MIRROR IMAGE. BALCONY SQUARE FOOTAGES ARE ESTIMATED AND MAY VARY FROM THAT STATED. PLEASE SEE SALES REPRESENTATIVE FOR DETAILS. FURNITURE NOT INCLUDED. REFER TO KEY PLAN FOR UNIT LOCATION AND ORIENTATION. PREPARED JUNE 9, 2022

1B+D-G

INTERIOR 571 SF | EXTERIOR 59 SF
1 BEDROOM+DEN, 1 BATH

FORÊT™

FOREST HILL

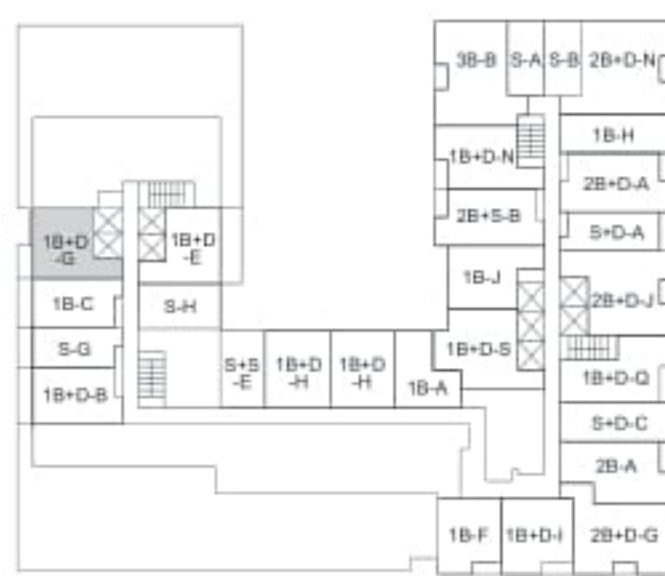
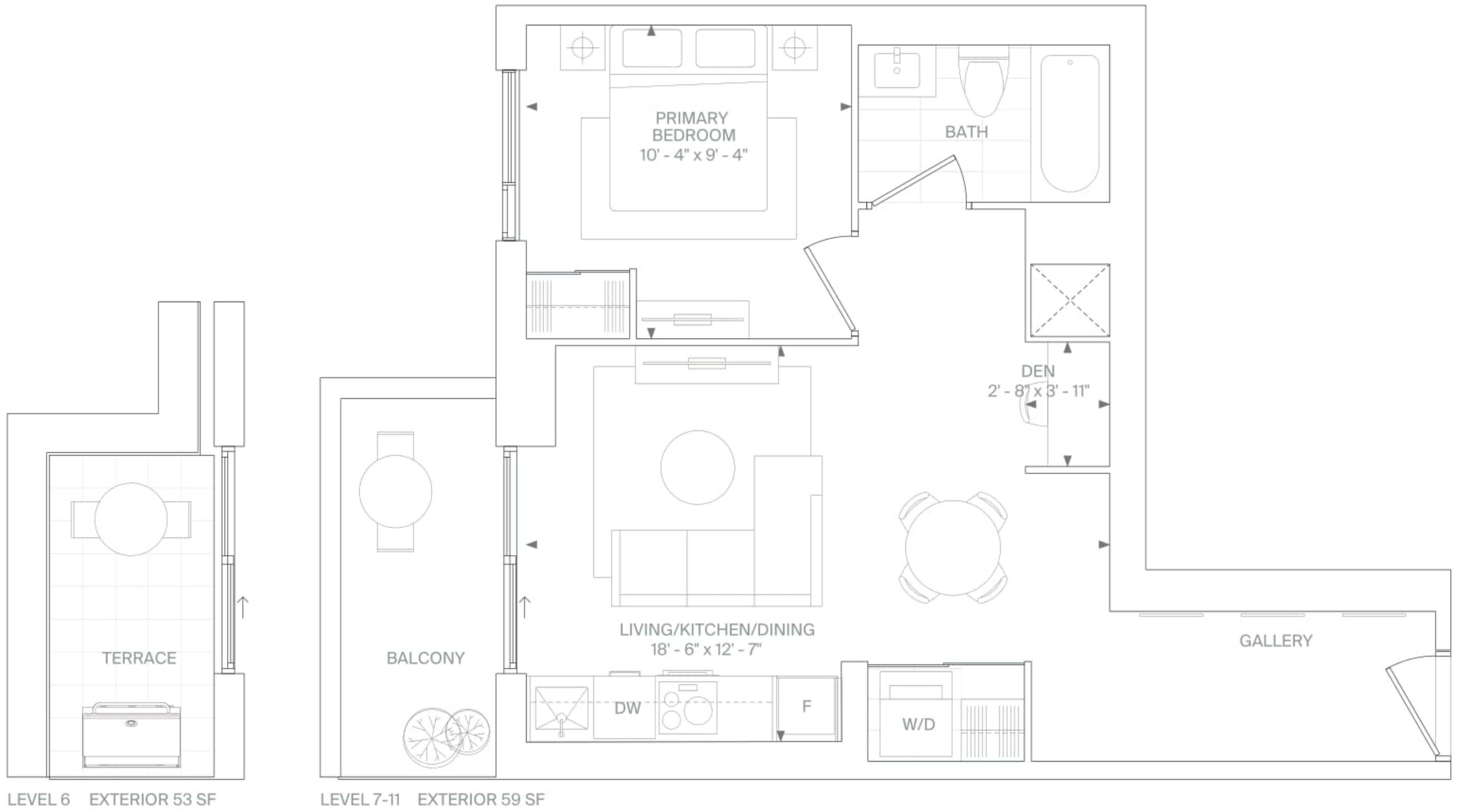

PODIUM LEVEL 6

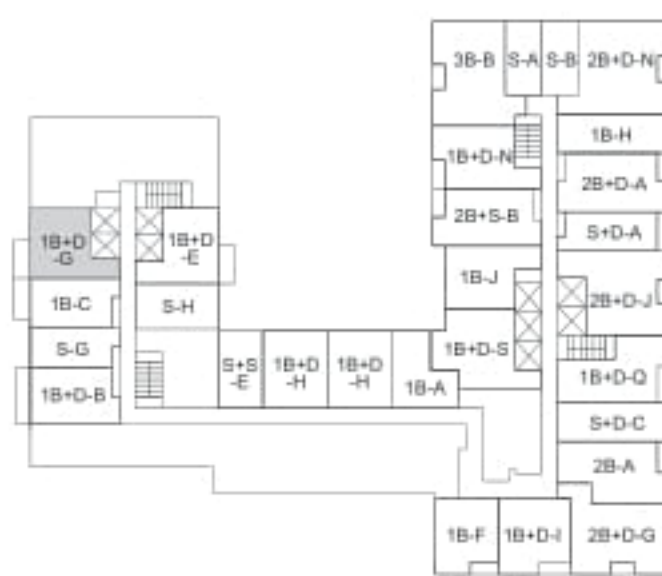

PODIUM LEVEL 7

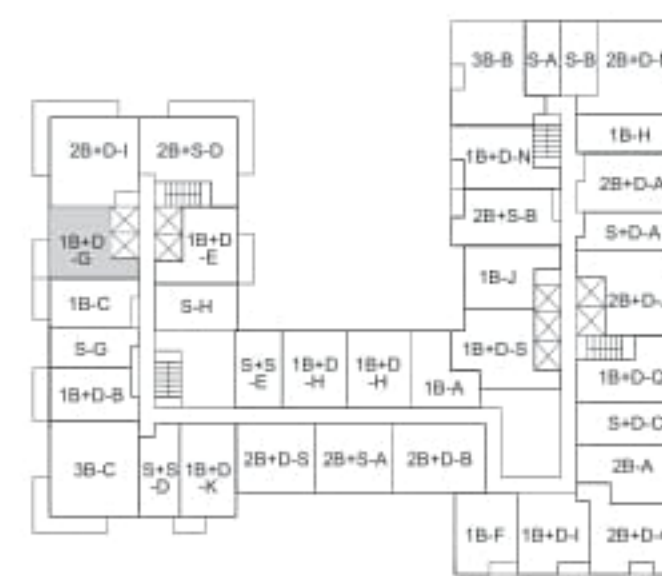

PODIUM LEVEL 8

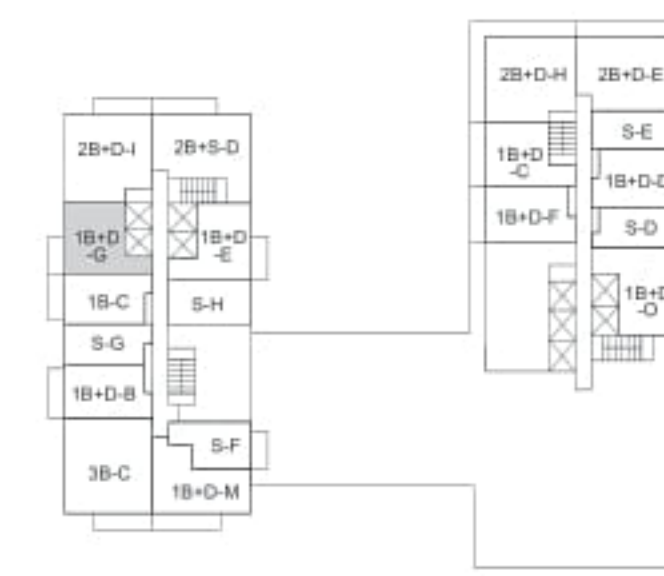

PODIUM LEVEL 9

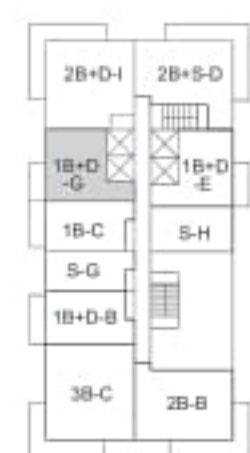

TOWER 2 LEVEL 10

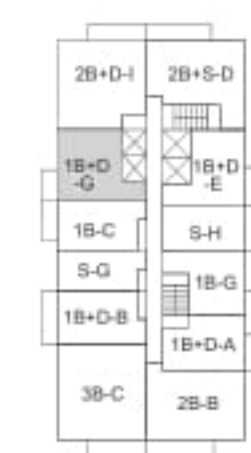

TOWER 2 LEVEL 11

ALL DIMENSIONS AND SPECIFICATIONS ARE APPROXIMATE. CERTAIN PLANS ARE REVERSE OR MIRROR IMAGE. BALCONY SQUARE FOOTAGES ARE ESTIMATED AND MAY VARY FROM THAT STATED. PLEASE SEE SALES REPRESENTATIVE FOR DETAILS. FURNITURE NOT INCLUDED. REFER TO KEY PLAN FOR UNIT LOCATION AND ORIENTATION. PREPARED JUNE 9, 2022

1B+D-H

INTERIOR 577 SF
 1 BEDROOM+DEN (BF), 1 BATH

FORÊT™

FOREST HILL

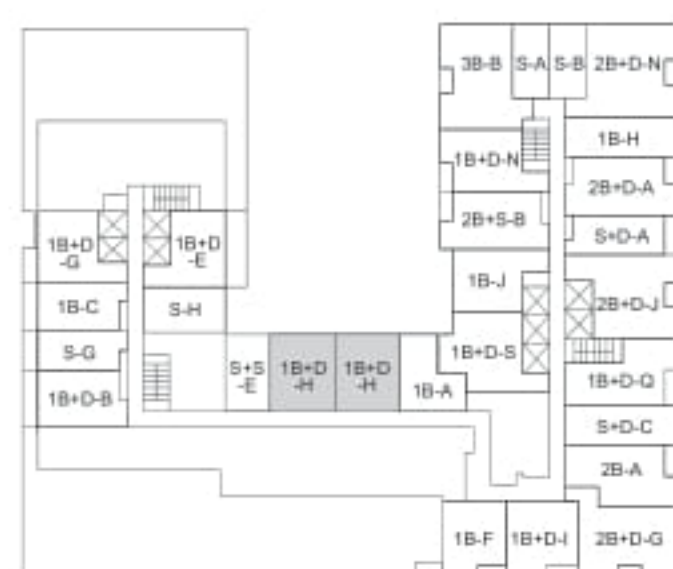
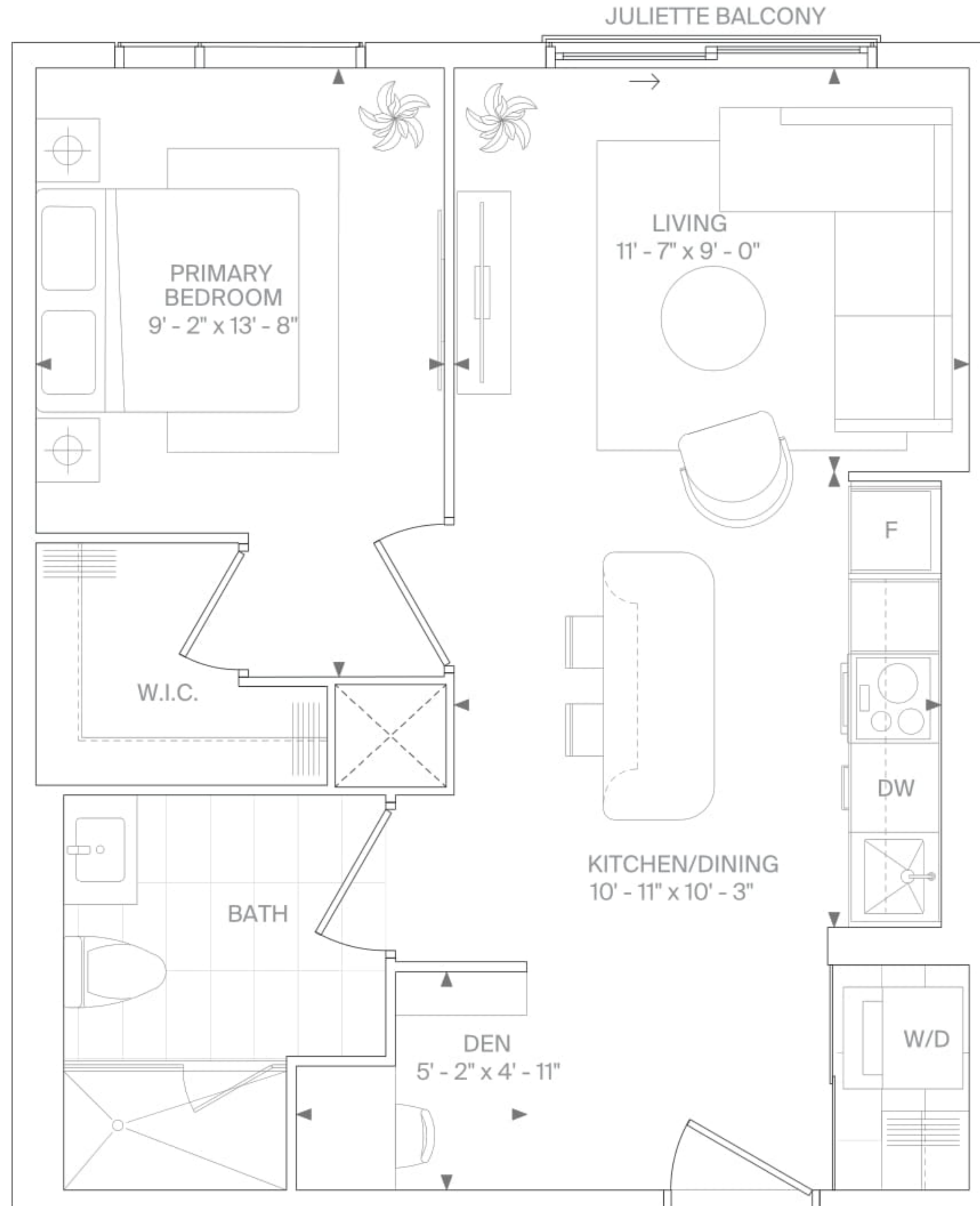

PODIUM LEVEL 6

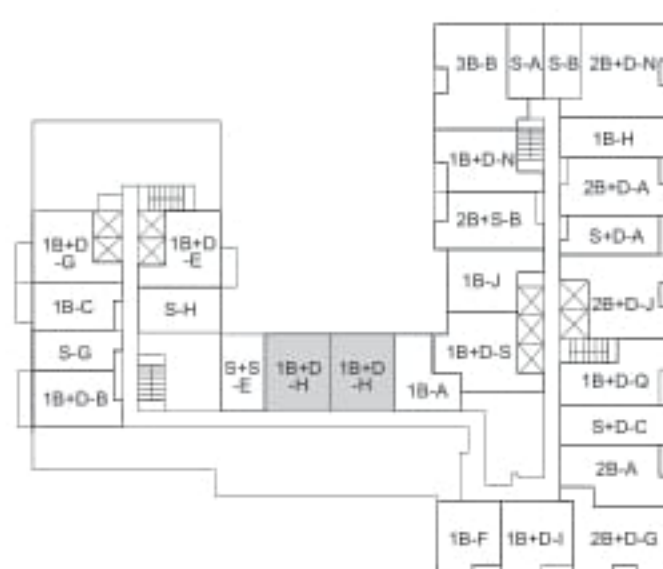

PODIUM LEVEL 7

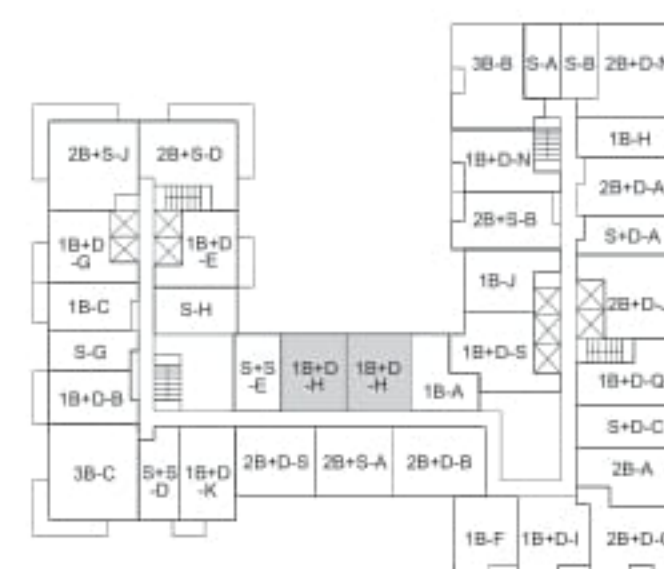

PODIUM LEVEL 8

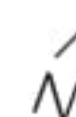

ALL DIMENSIONS AND SPECIFICATIONS ARE APPROXIMATE. CERTAIN PLANS ARE REVERSE OR MIRROR IMAGE. BALCONY SQUARE FOOTAGES ARE ESTIMATED AND MAY VARY FROM THAT STATED. PLEASE SEE SALES REPRESENTATIVE FOR DETAILS. FURNITURE NOT INCLUDED. REFER TO KEY PLAN FOR UNIT LOCATION AND ORIENTATION. PREPARED JUNE 9, 2022

1B+D-J

INTERIOR 596 SF
1 BEDROOM+DEN(BF), 1 BATH

FORÊT™

FOREST HILL

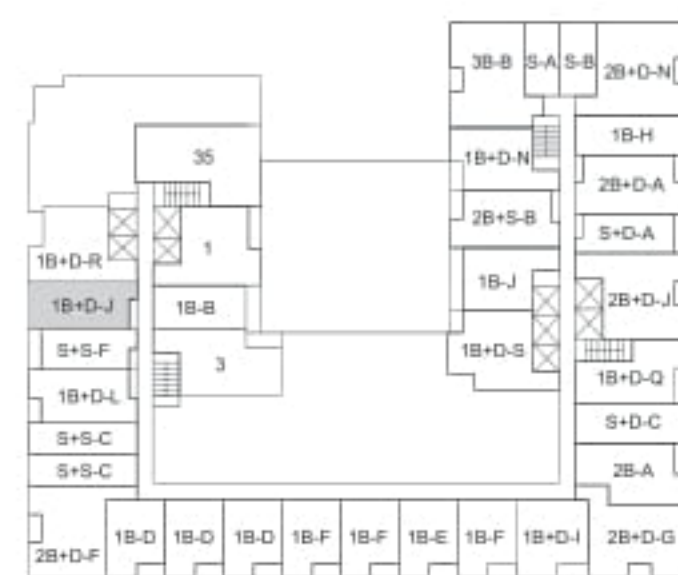
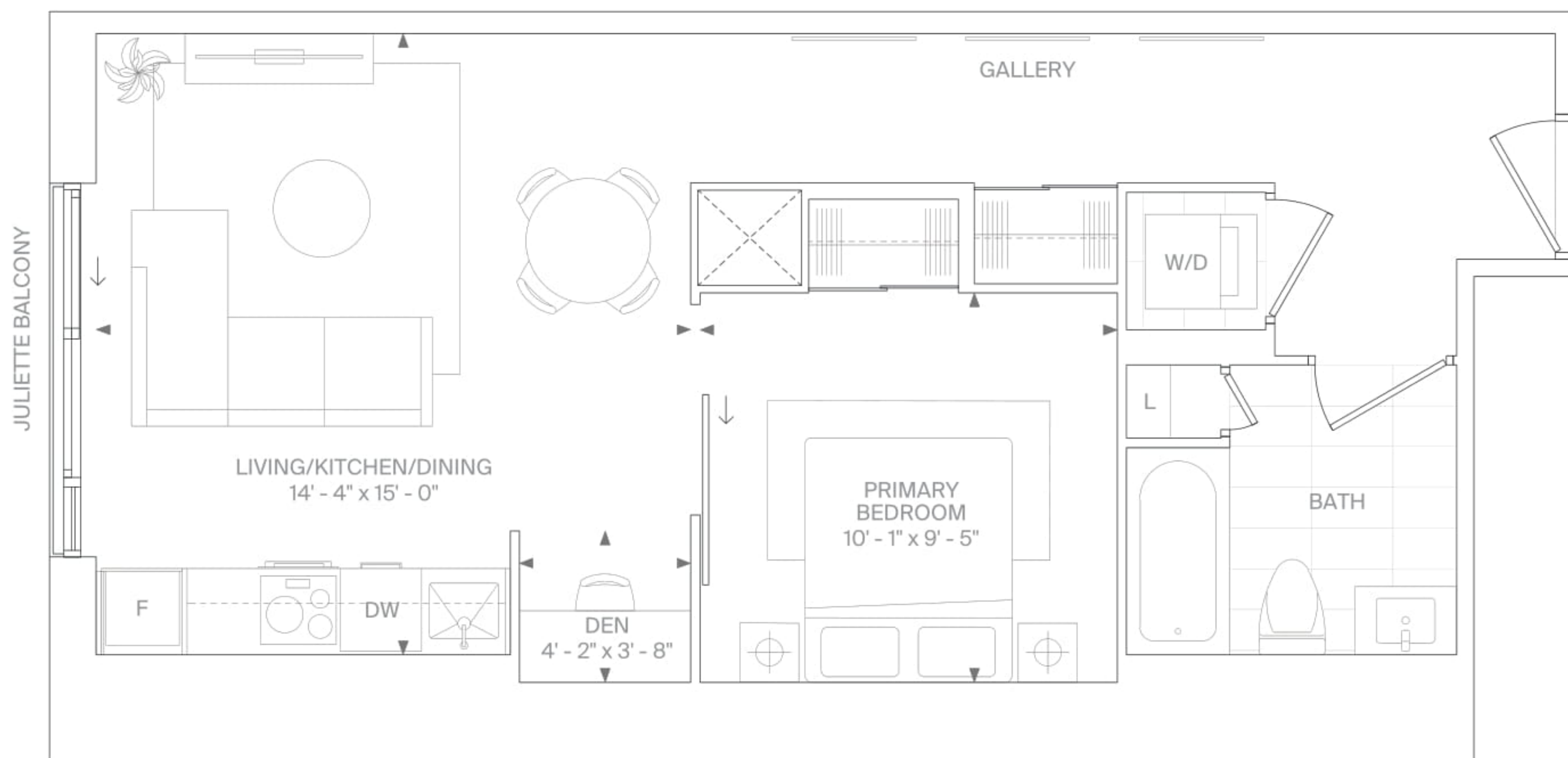

PODIUM LEVEL 2

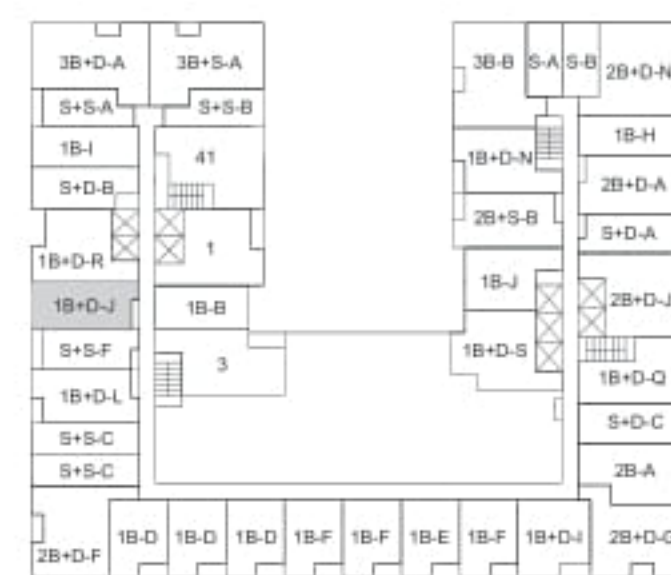

PODIUM LEVEL 3 - 5



ALL DIMENSIONS AND SPECIFICATIONS ARE APPROXIMATE. CERTAIN PLANS ARE REVERSE OR MIRROR IMAGE. BALCONY SQUARE FOOTAGES ARE ESTIMATED AND MAY VARY FROM THAT STATED. PLEASE SEE SALES REPRESENTATIVE FOR DETAILS. FURNITURE NOT INCLUDED. REFER TO KEY PLAN FOR UNIT LOCATION AND ORIENTATION. PREPARED JUNE 9, 2022

1B+D-K

INTERIOR 600 SF | EXTERIOR 46 SF
1 BEDROOM+DEN, 2 BATH

FORÊT™

FOREST HILL

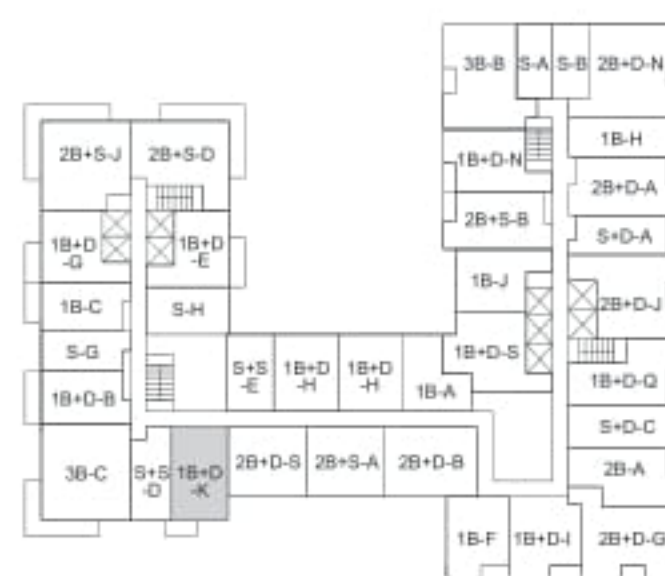
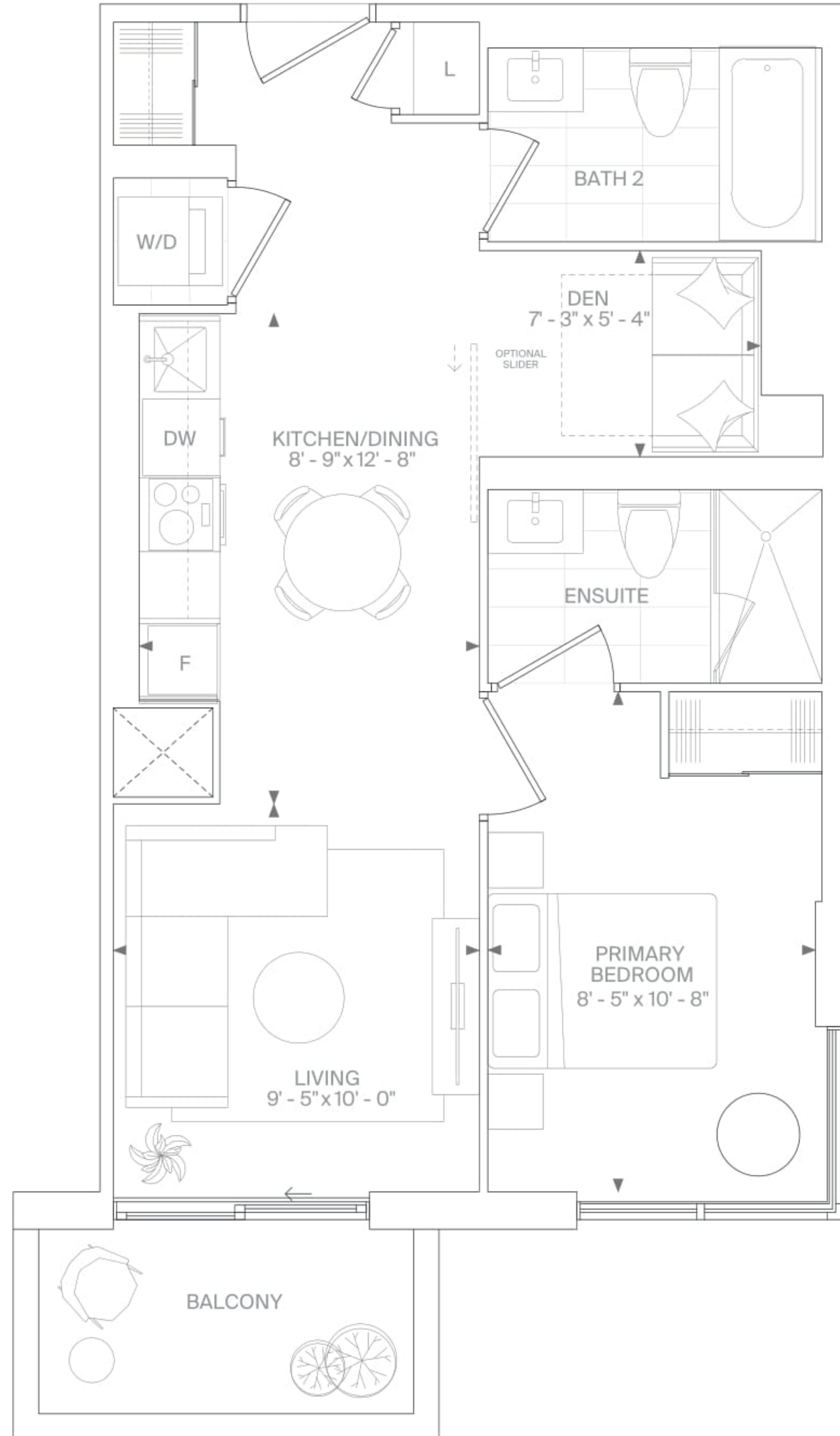

PODIUM LEVEL 8

ALL DIMENSIONS AND SPECIFICATIONS ARE APPROXIMATE. CERTAIN PLANS ARE REVERSE OR MIRROR IMAGE. BALCONY SQUARE FOOTAGES ARE ESTIMATED AND MAY VARY FROM THAT STATED. PLEASE SEE SALES REPRESENTATIVE FOR DETAILS. FURNITURE NOT INCLUDED. REFER TO KEY PLAN FOR UNIT LOCATION AND ORIENTATION. PREPARED JUNE 9, 2022

1B+D-L

INTERIOR 612 SF | EXTERIOR 28 SF
1 BEDROOM+DEN, 1 BATH

FORÊT™

FOREST HILL

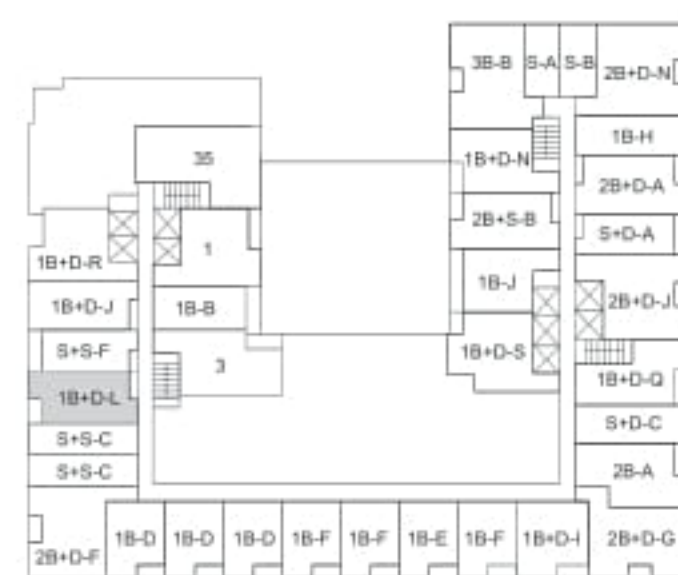
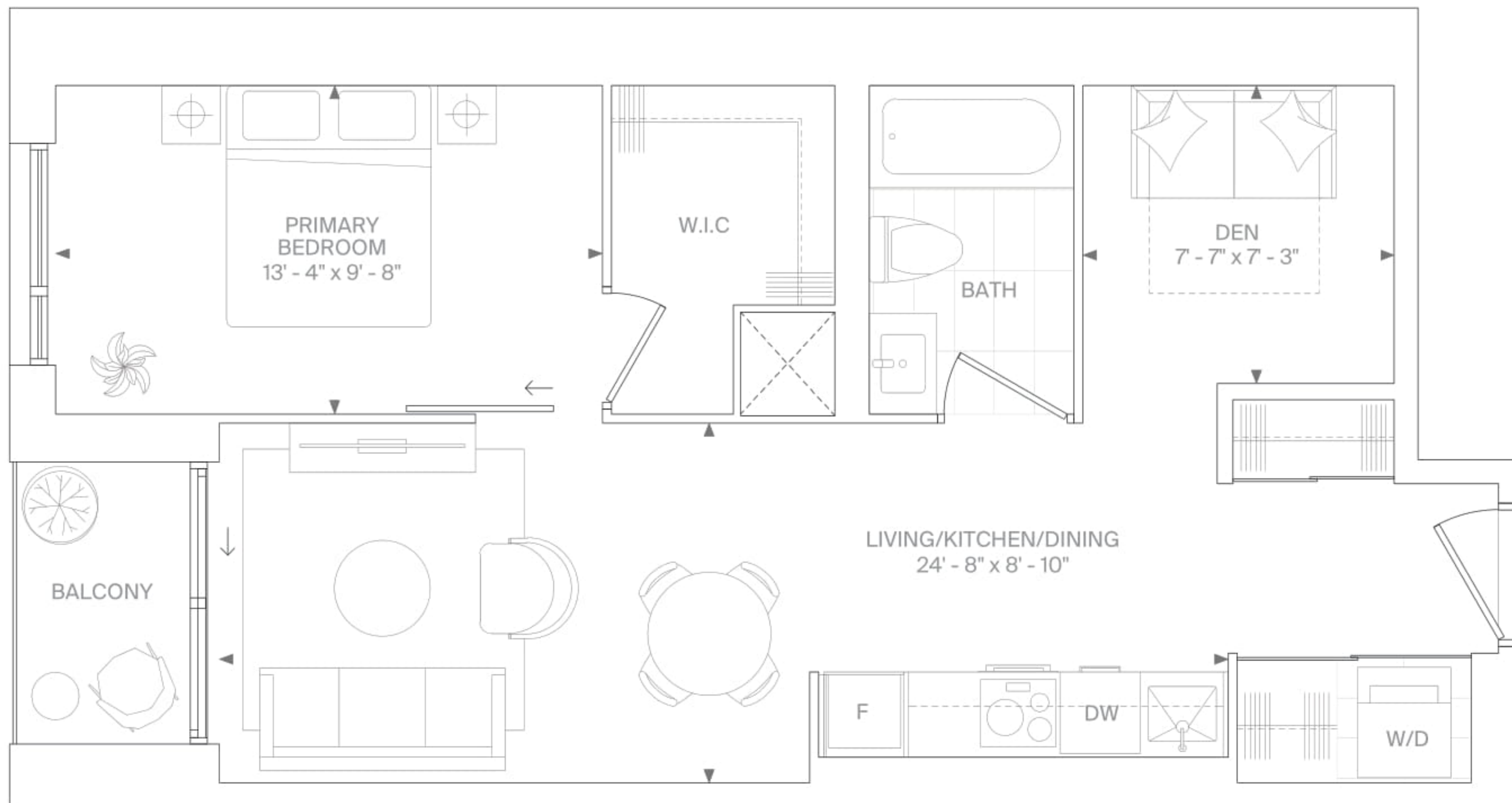

PODIUM LEVEL 2

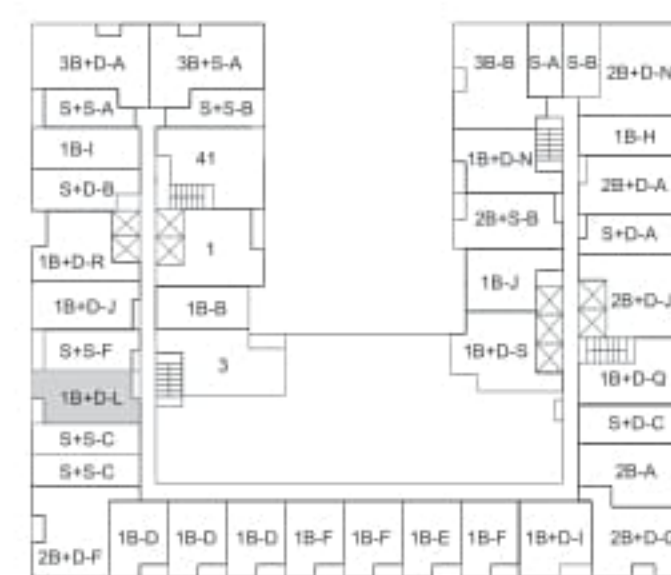

PODIUM LEVEL 3 - 5



ALL DIMENSIONS AND SPECIFICATIONS ARE APPROXIMATE. CERTAIN PLANS ARE REVERSE OR MIRROR IMAGE. BALCONY SQUARE FOOTAGES ARE ESTIMATED AND MAY VARY FROM THAT STATED. PLEASE SEE SALES REPRESENTATIVE FOR DETAILS. FURNITURE NOT INCLUDED. REFER TO KEY PLAN FOR UNIT LOCATION AND ORIENTATION. PREPARED JUNE 9, 2022

1B+D-M

INTERIOR 618 SF | EXTERIOR 108 SF
1 BEDROOM+DEN, 1 BATH

FORÊT™

FOREST HILL

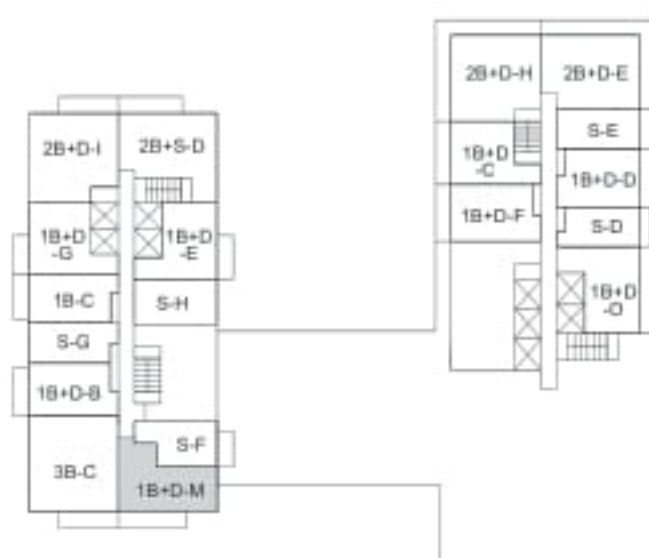
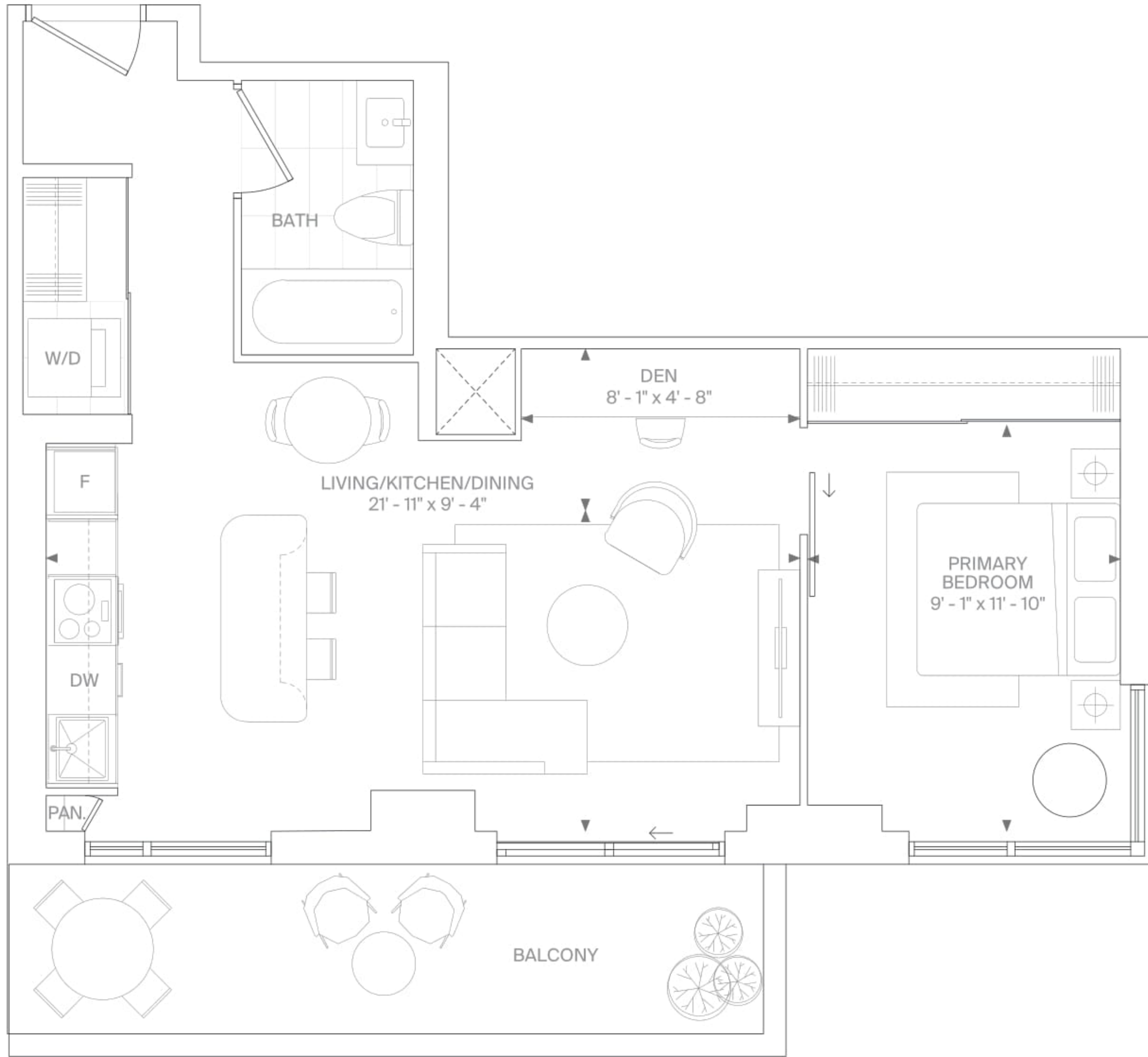

PODIUM LEVEL 9

ALL DIMENSIONS AND SPECIFICATIONS ARE APPROXIMATE. CERTAIN PLANS ARE REVERSE OR MIRROR IMAGE. BALCONY SQUARE FOOTAGES ARE ESTIMATED AND MAY VARY FROM THAT STATED. PLEASE SEE SALES REPRESENTATIVE FOR DETAILS. FURNITURE NOT INCLUDED. REFER TO KEY PLAN FOR UNIT LOCATION AND ORIENTATION. PREPARED JUNE 9, 2022

1B+D-P

INTERIOR 651 SF | EXTERIOR 59 SF
 1 BEDROOM+DEN(BF), 2 BATH

FORÊT™

FOREST HILL

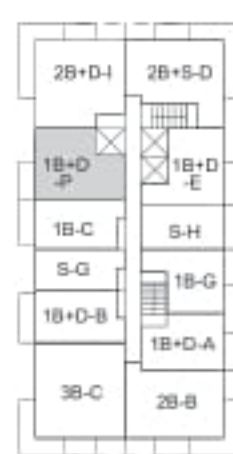
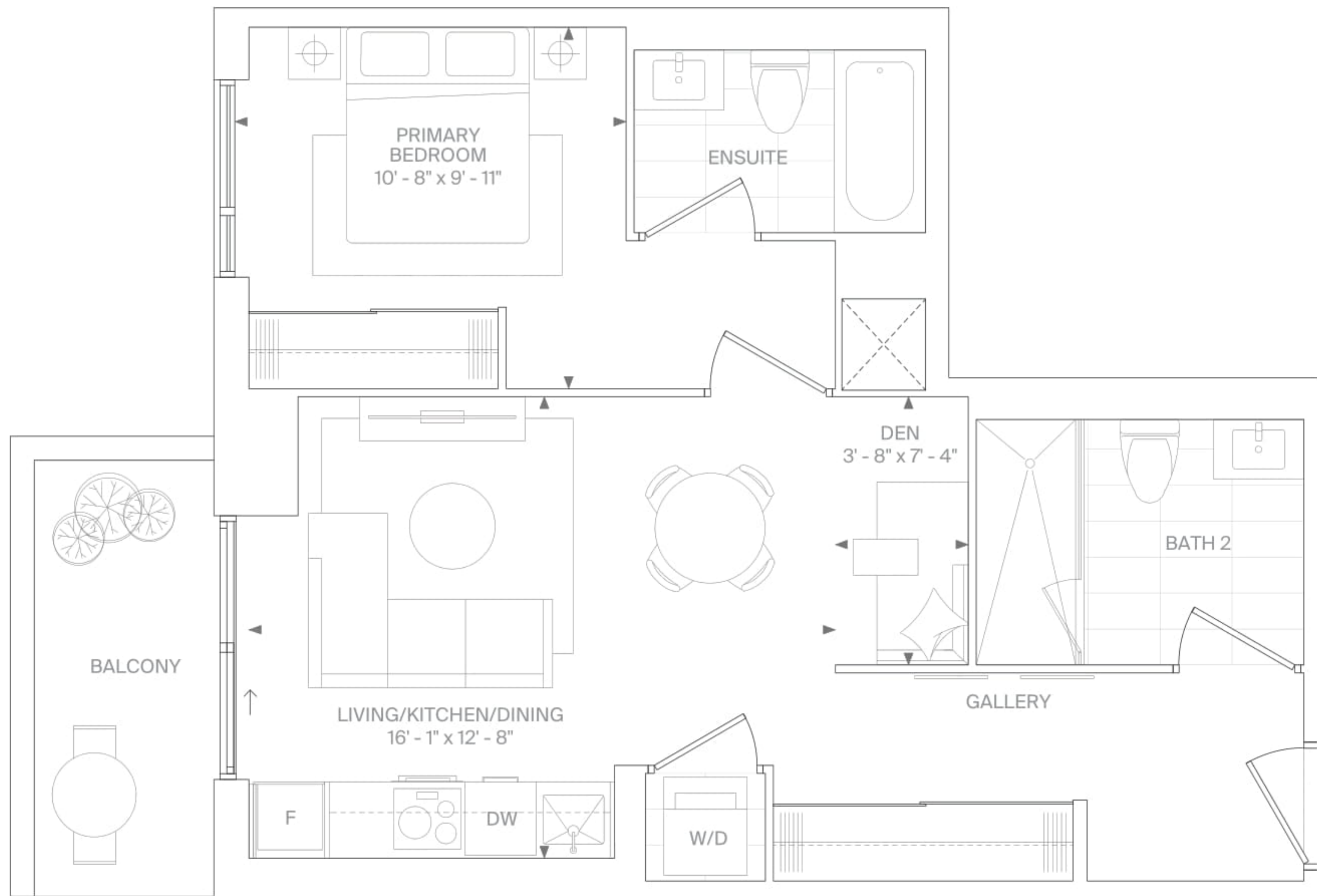

TOWER 2 LEVEL 12 - 29

ALL DIMENSIONS AND SPECIFICATIONS ARE APPROXIMATE. CERTAIN PLANS ARE REVERSE OR MIRROR IMAGE. BALCONY SQUARE FOOTAGES ARE ESTIMATED AND MAY VARY FROM THAT STATED. PLEASE SEE SALES REPRESENTATIVE FOR DETAILS. FURNITURE NOT INCLUDED. REFER TO KEY PLAN FOR UNIT LOCATION AND ORIENTATION. PREPARED JUNE 9, 2022

1B+D-T

INTERIOR 775 SF | EXTERIOR 52 SF
 1 BEDROOM+DEN (BF), 1 BATH

FORÊT™

FOREST HILL

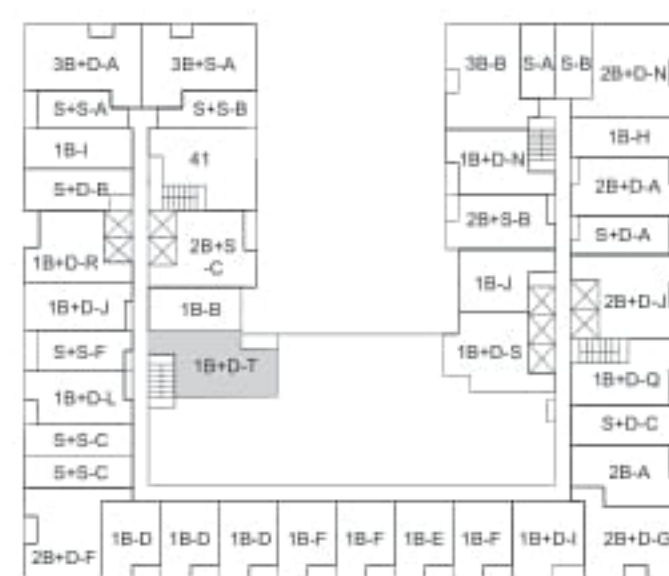
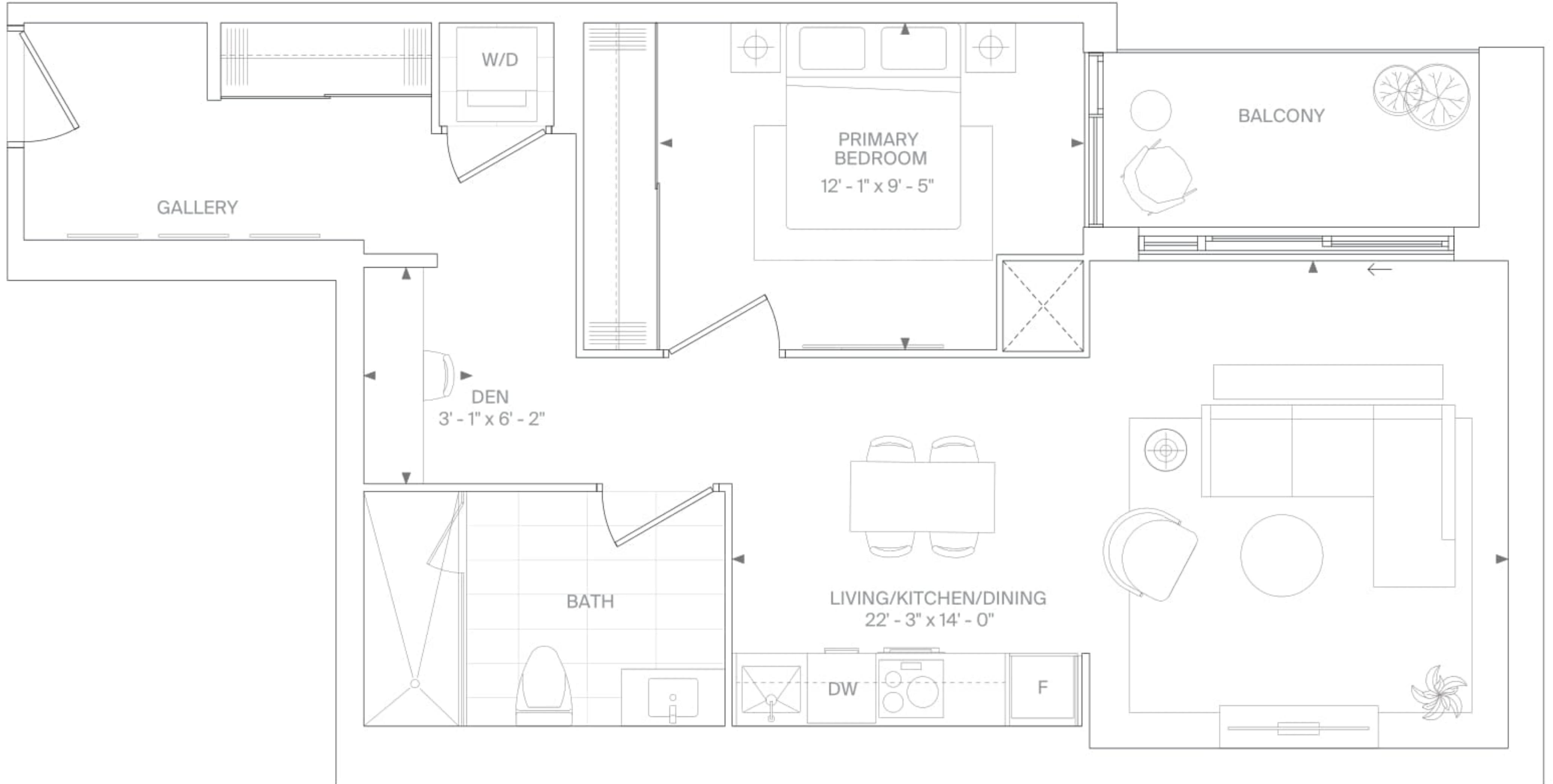

PODIUM LEVEL 4 - 5

ALL DIMENSIONS AND SPECIFICATIONS ARE APPROXIMATE. CERTAIN PLANS ARE REVERSE OR MIRROR IMAGE. BALCONY SQUARE FOOTAGES ARE ESTIMATED AND MAY VARY FROM THAT STATED. PLEASE SEE SALES REPRESENTATIVE FOR DETAILS. FURNITURE NOT INCLUDED. REFER TO KEY PLAN FOR UNIT LOCATION AND ORIENTATION. PREPARED JUNE 9, 2022

2B-B

FORÊT™

FOREST HILL

INTERIOR 784 SF | EXTERIOR 188 SF
2 BEDROOM, 2 BATH

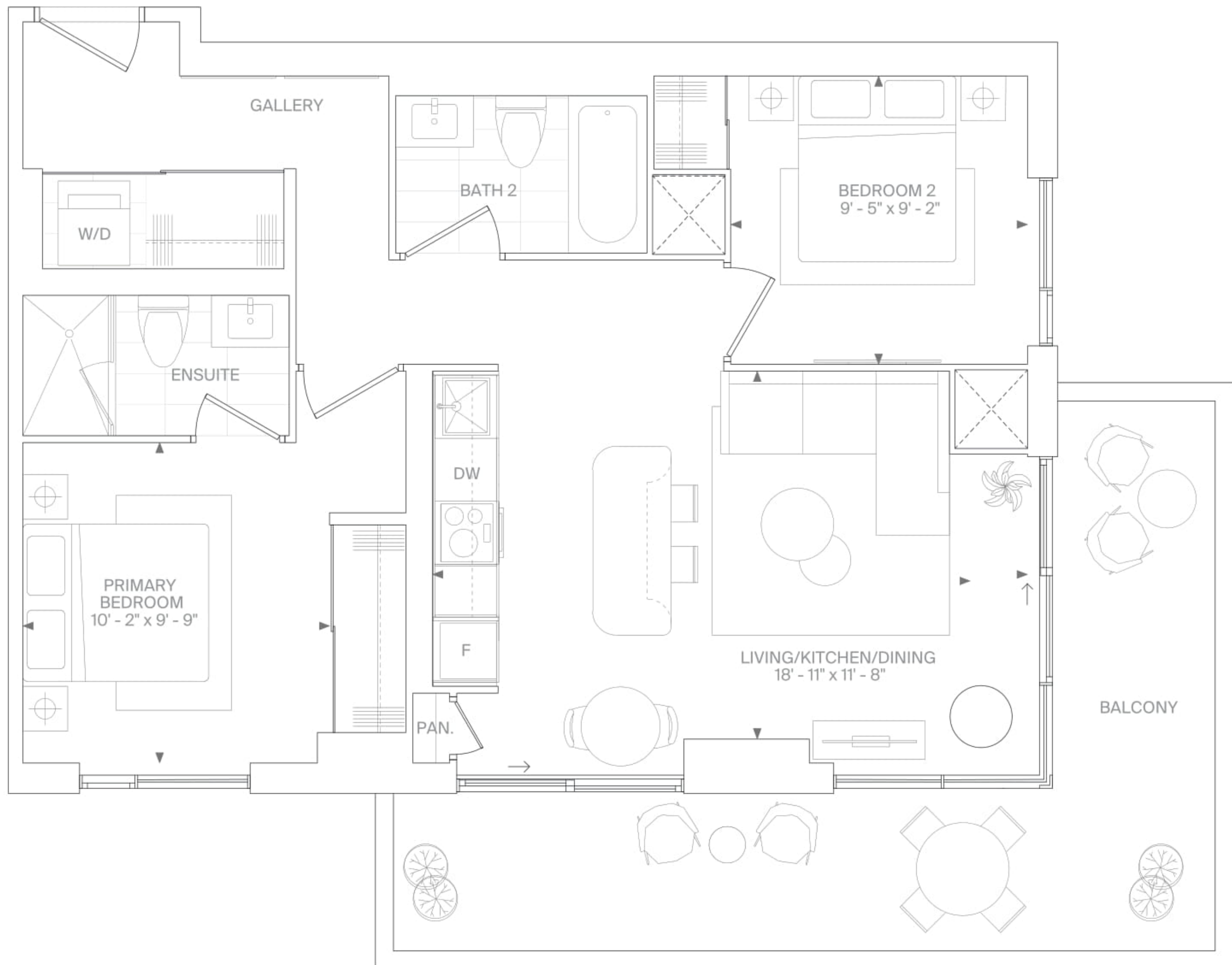

LEVEL 10, 12, 14, 16, 18, 20, 22, 24, 26, 28
EXTERIOR 188 SF

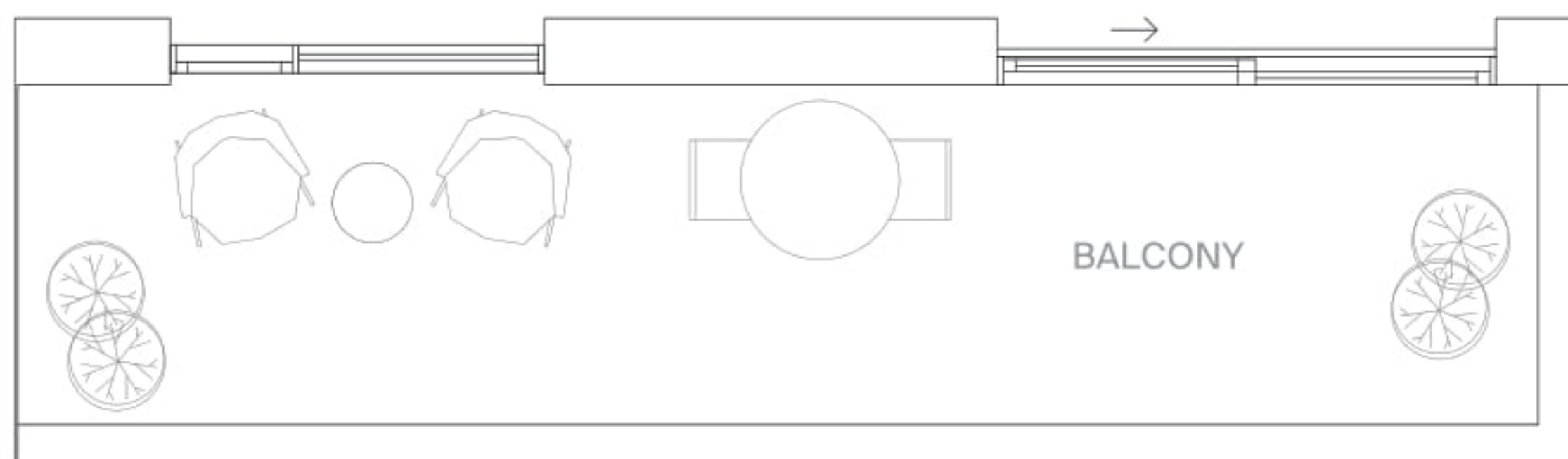

LEVEL 11, 13, 15, 17, 19, 21, 23, 25, 27, 29
EXTERIOR 108 SF

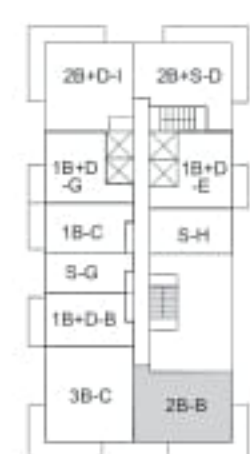

TOWER 2 LEVEL 10

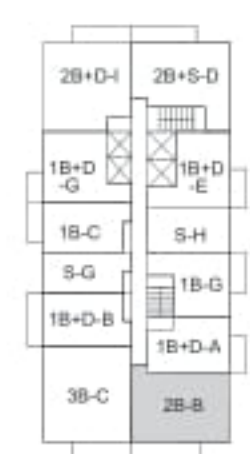

TOWER 2 LEVEL 11



TOWER 2 LEVEL 12 - 29



ALL DIMENSIONS AND SPECIFICATIONS ARE APPROXIMATE. CERTAIN PLANS ARE REVERSE OR MIRROR IMAGE. BALCONY SQUARE FOOTAGES ARE ESTIMATED AND MAY VARY FROM THAT STATED. PLEASE SEE SALES REPRESENTATIVE FOR DETAILS. FURNITURE NOT INCLUDED. REFER TO KEY PLAN FOR UNIT LOCATION AND ORIENTATION. PREPARED JUNE 9, 2022

2B-C

INTERIOR 863 SF | EXTERIOR 208 SF
2 BEDROOM, 2 BATH

FORÊT™

FOREST HILL

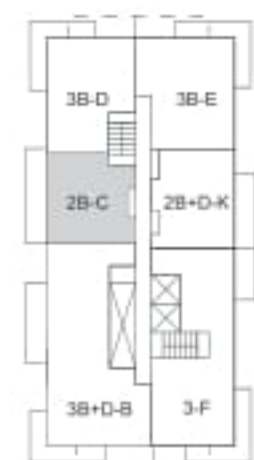
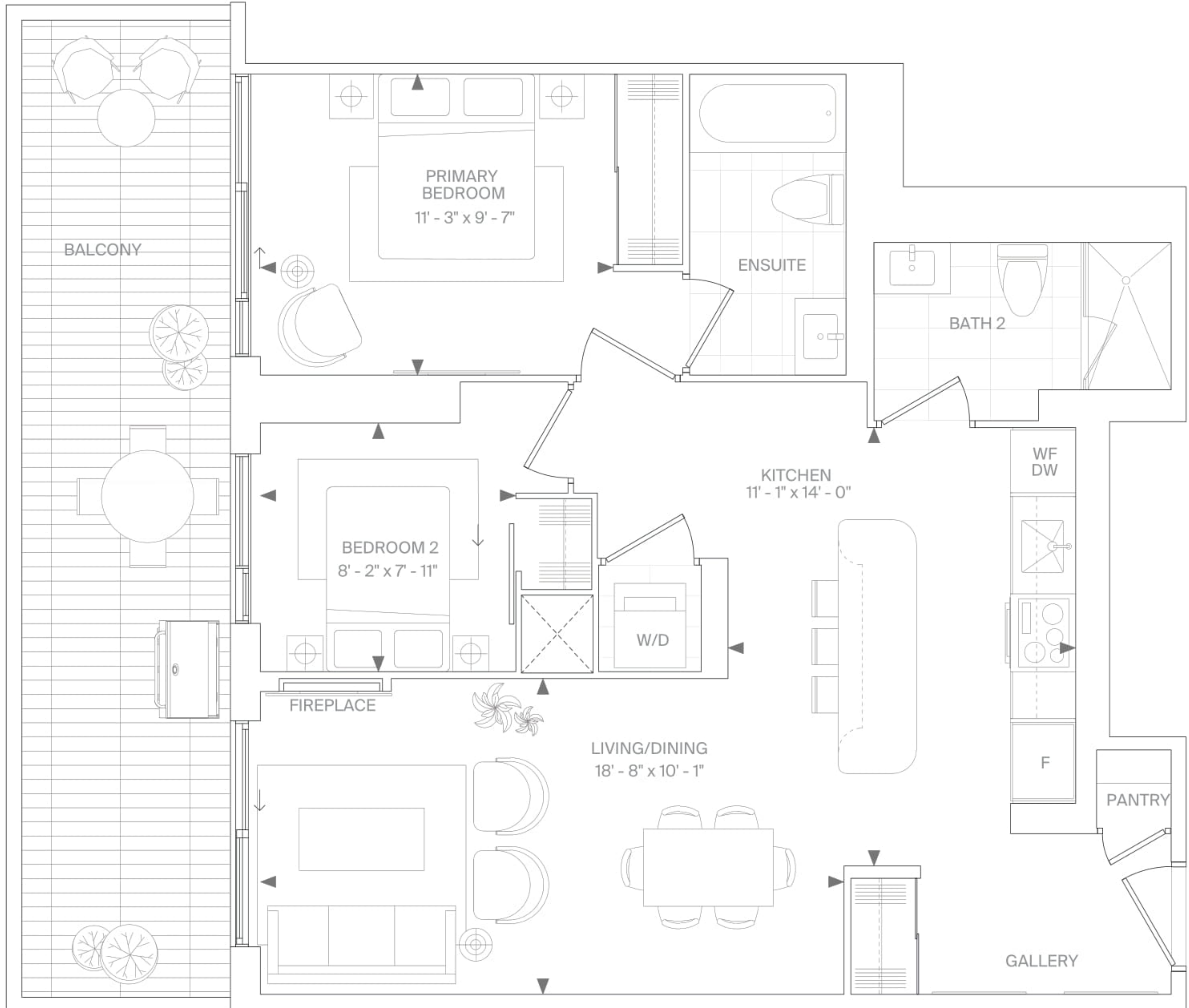

TOWER 3 LEVEL 23 - 24



TOWER 3 LEVEL 25 - 29



TOWER 3 LEVEL 30



TOWER 3 LEVEL 31



ALL DIMENSIONS AND SPECIFICATIONS ARE APPROXIMATE. CERTAIN PLANS ARE REVERSE OR MIRROR IMAGE. BALCONY SQUARE FOOTAGES ARE ESTIMATED AND MAY VARY FROM THAT STATED. PLEASE SEE SALES REPRESENTATIVE FOR DETAILS. FURNITURE NOT INCLUDED. REFER TO KEY PLAN FOR UNIT LOCATION AND ORIENTATION. PREPARED JUNE 9, 2022

2B+D-1

INTERIOR 879 SF | EXTERIOR 220 SF
2 BEDROOM+DEN (BF), 2 BATH

FORÊT™

FOREST HILL

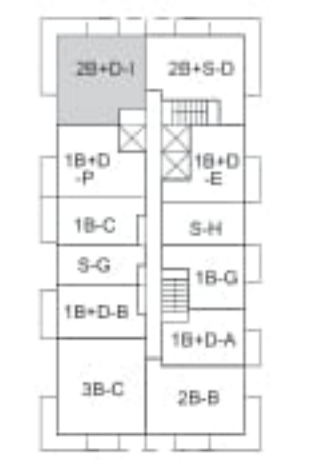
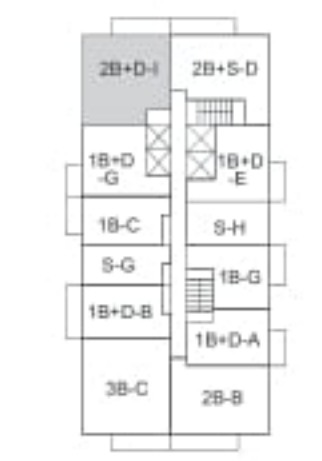
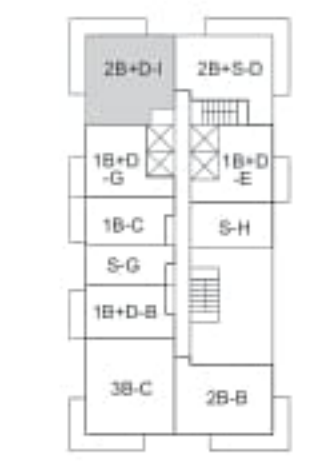
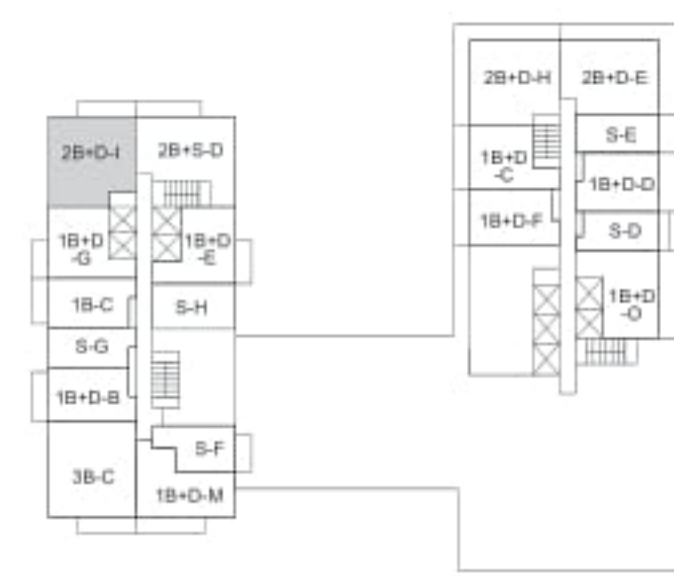
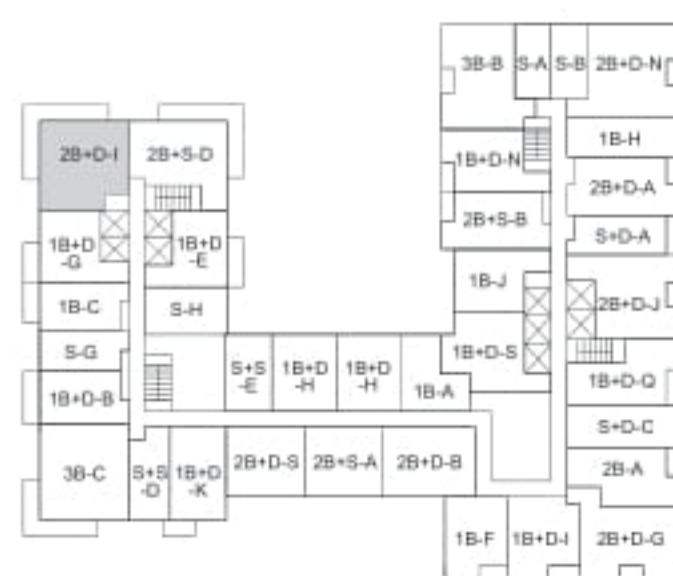
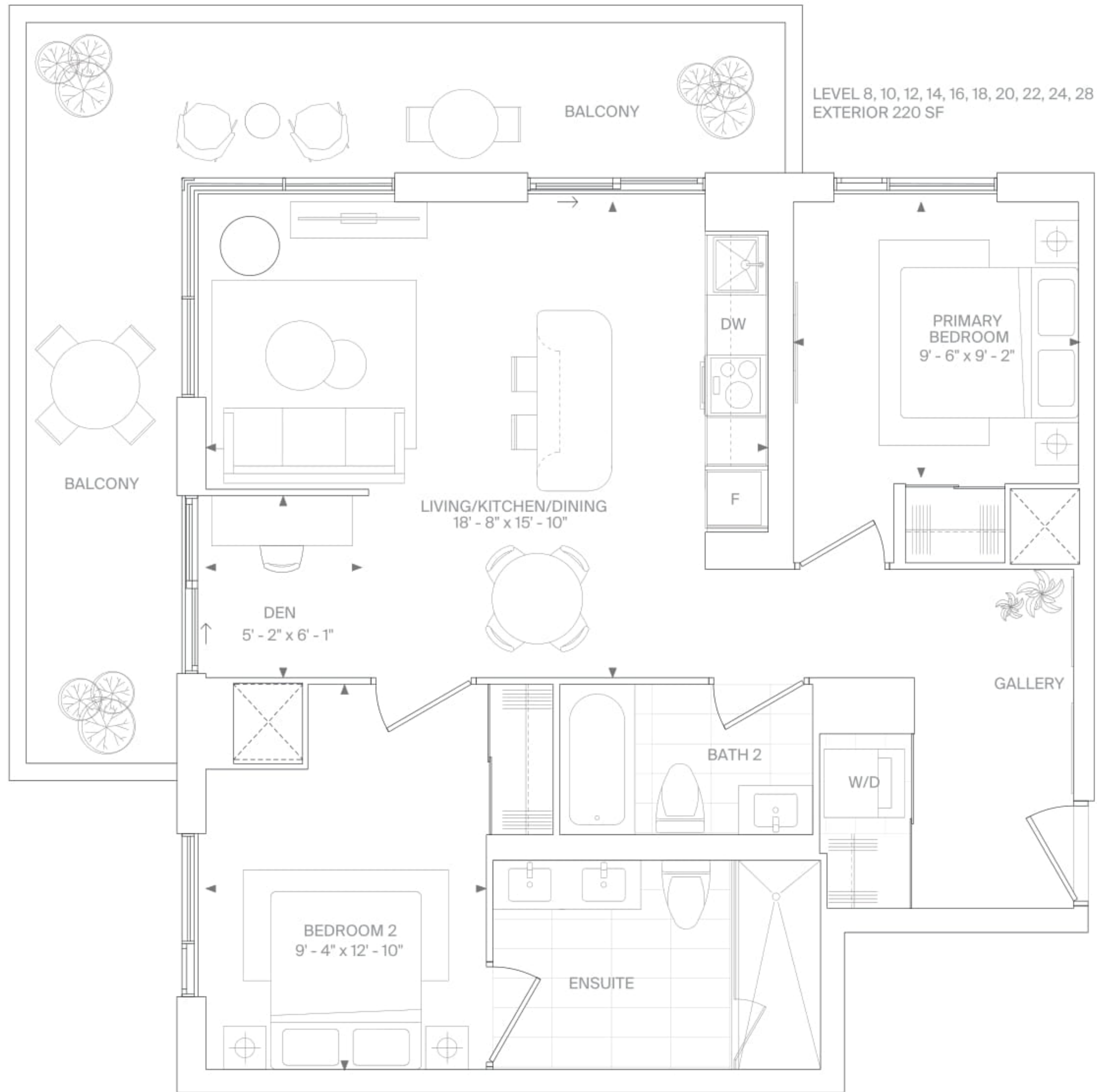
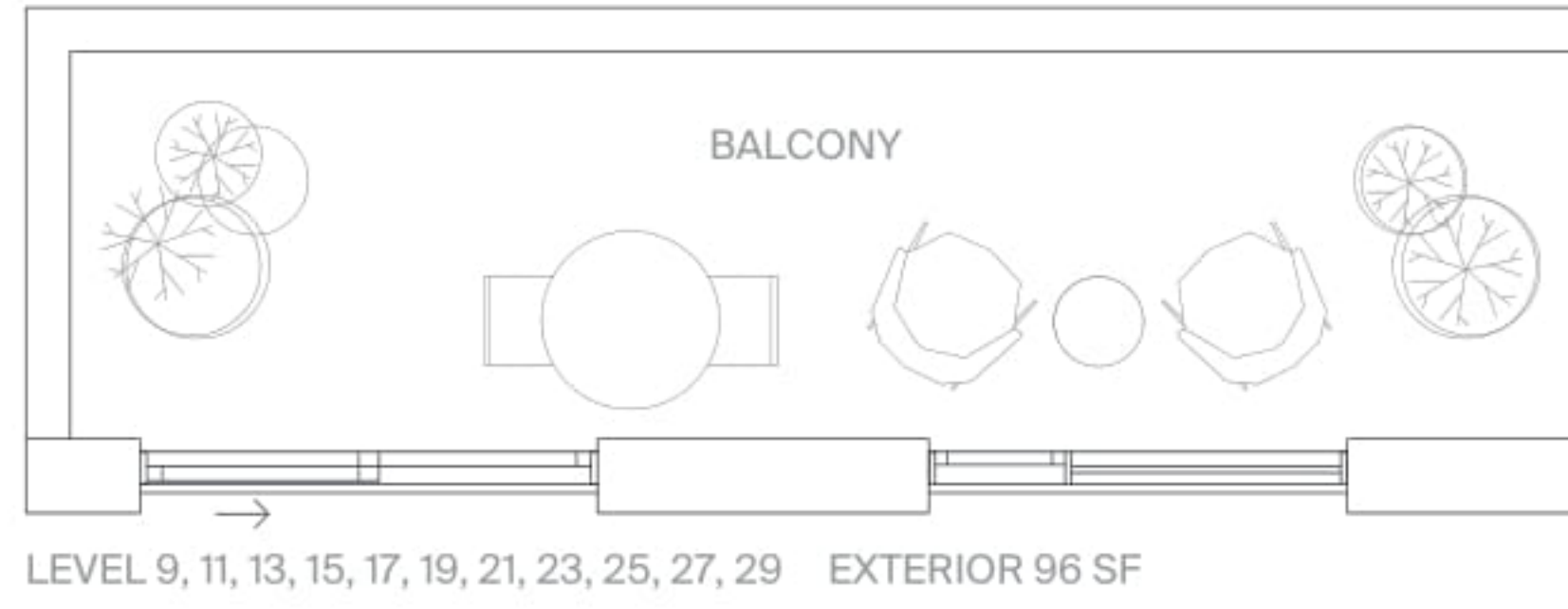

ALL DIMENSIONS AND SPECIFICATIONS ARE APPROXIMATE. CERTAIN PLANS ARE REVERSE OR MIRROR IMAGE. BALCONY SQUARE FOOTAGES ARE ESTIMATED AND MAY VARY FROM THAT STATED. PLEASE SEE SALES REPRESENTATIVE FOR DETAILS. FURNITURE NOT INCLUDED. REFER TO KEY PLAN FOR UNIT LOCATION AND ORIENTATION. PREPARED JUNE 9, 2022

2B+S-A

INTERIOR 638 SF
2 BEDROOM+STUDY, 2 BATH

FORÊT™

FOREST HILL

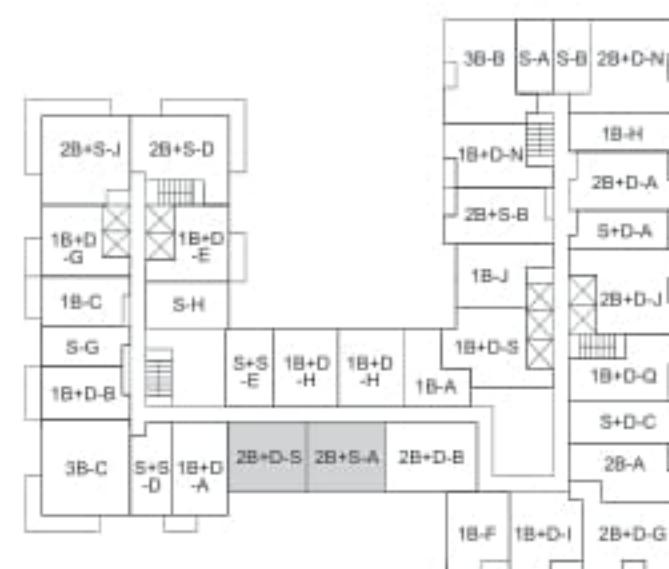
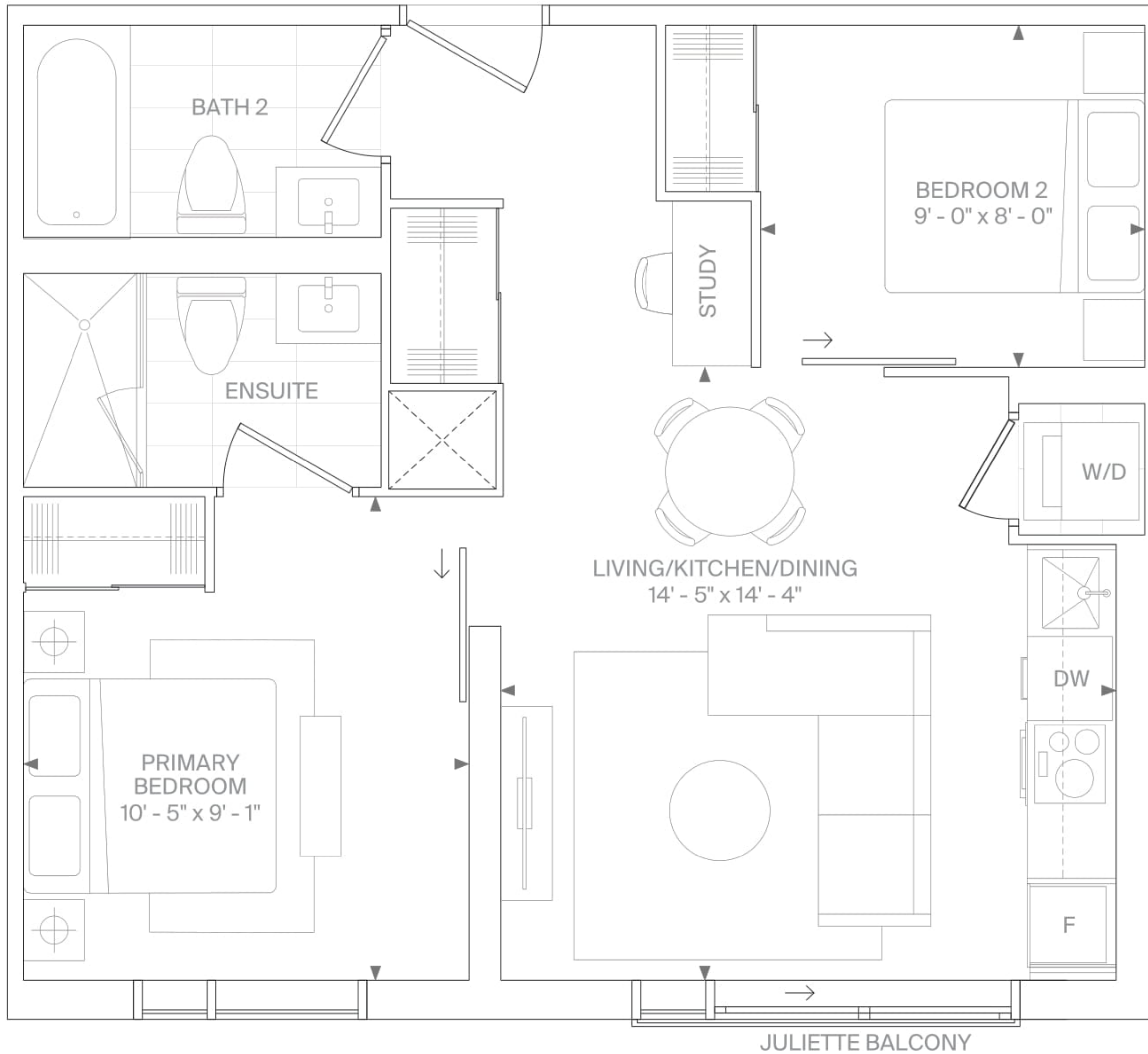

PODIUM LEVEL 8

ALL DIMENSIONS AND SPECIFICATIONS ARE APPROXIMATE. CERTAIN PLANS ARE REVERSE OR MIRROR IMAGE. BALCONY SQUARE FOOTAGES ARE ESTIMATED AND MAY VARY FROM THAT STATED. PLEASE SEE SALES REPRESENTATIVE FOR DETAILS. FURNITURE NOT INCLUDED. REFER TO KEY PLAN FOR UNIT LOCATION AND ORIENTATION. PREPARED JUNE 9, 2022

2B+S-C

INTERIOR 736 SF | EXTERIOR 49 SF
2 BEDROOM+STUDY, 2 BATH

FORÊT™

FOREST HILL

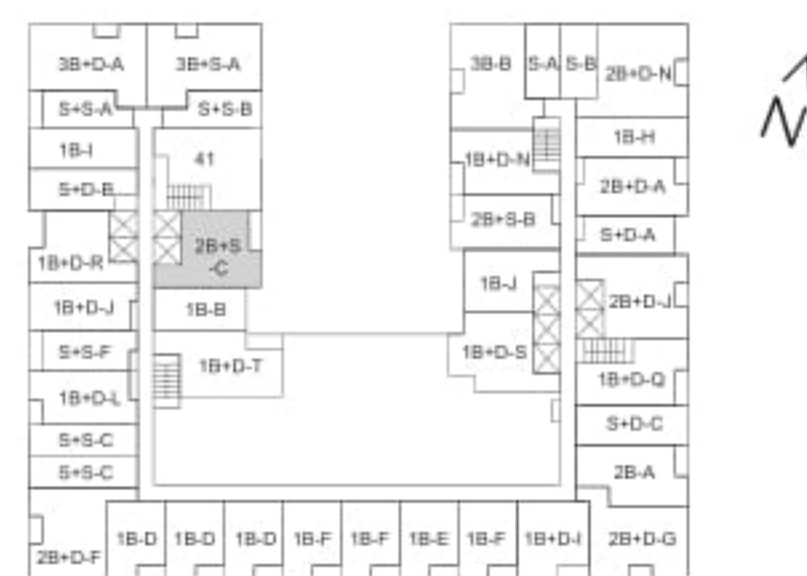
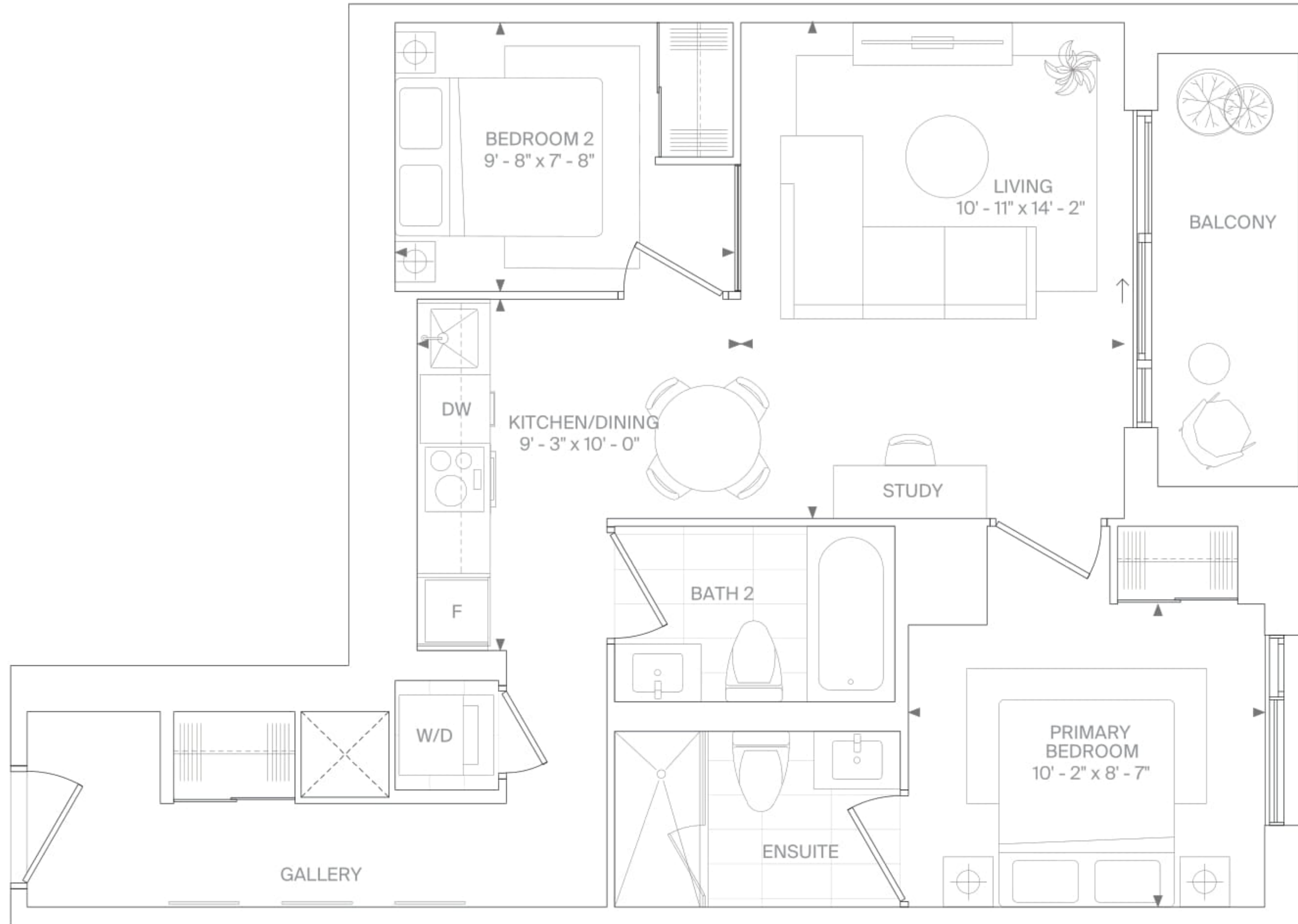

PODIUM LEVEL 4 - 5

ALL DIMENSIONS AND SPECIFICATIONS ARE APPROXIMATE. CERTAIN PLANS ARE REVERSE OR MIRROR IMAGE. BALCONY SQUARE FOOTAGES ARE ESTIMATED AND MAY VARY FROM THAT STATED. PLEASE SEE SALES REPRESENTATIVE FOR DETAILS. FURNITURE NOT INCLUDED. REFER TO KEY PLAN FOR UNIT LOCATION AND ORIENTATION. PREPARED JUNE 9, 2022

2B+S-D

INTERIOR 795 SF | EXTERIOR 234 SF
2 BEDROOM+STUDY, 2 BATH

FORÊT™

FOREST HILL

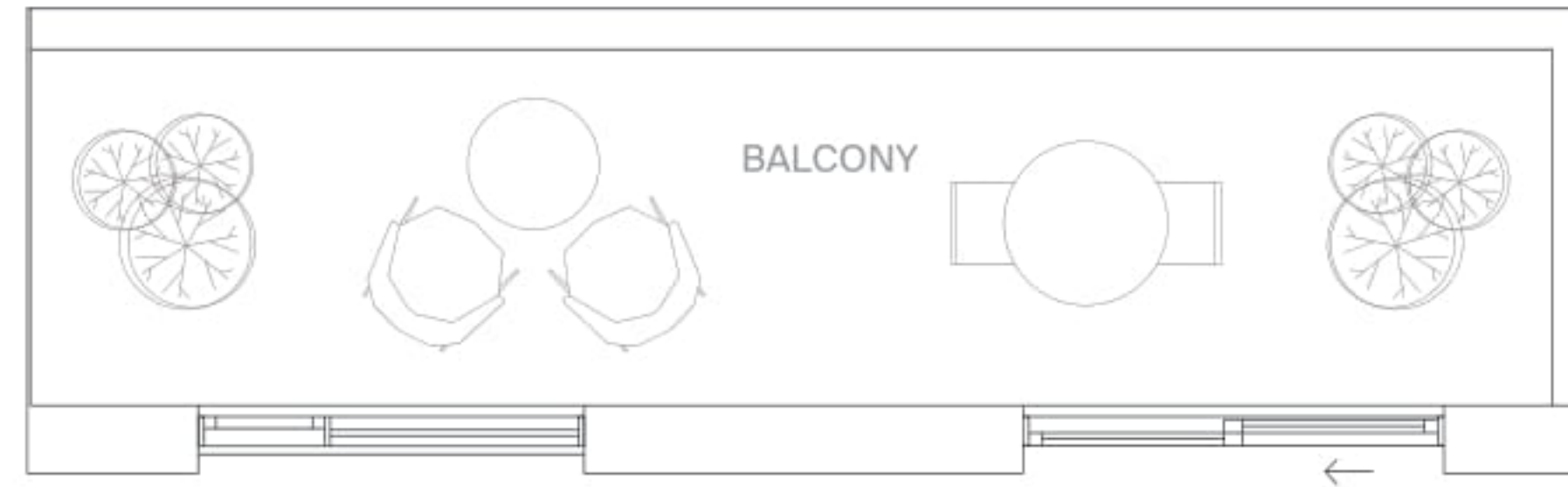

LEVEL 9, 11, 13, 15, 17, 19, 21, 23, 25, 27, 29 EXTERIOR 104 SF

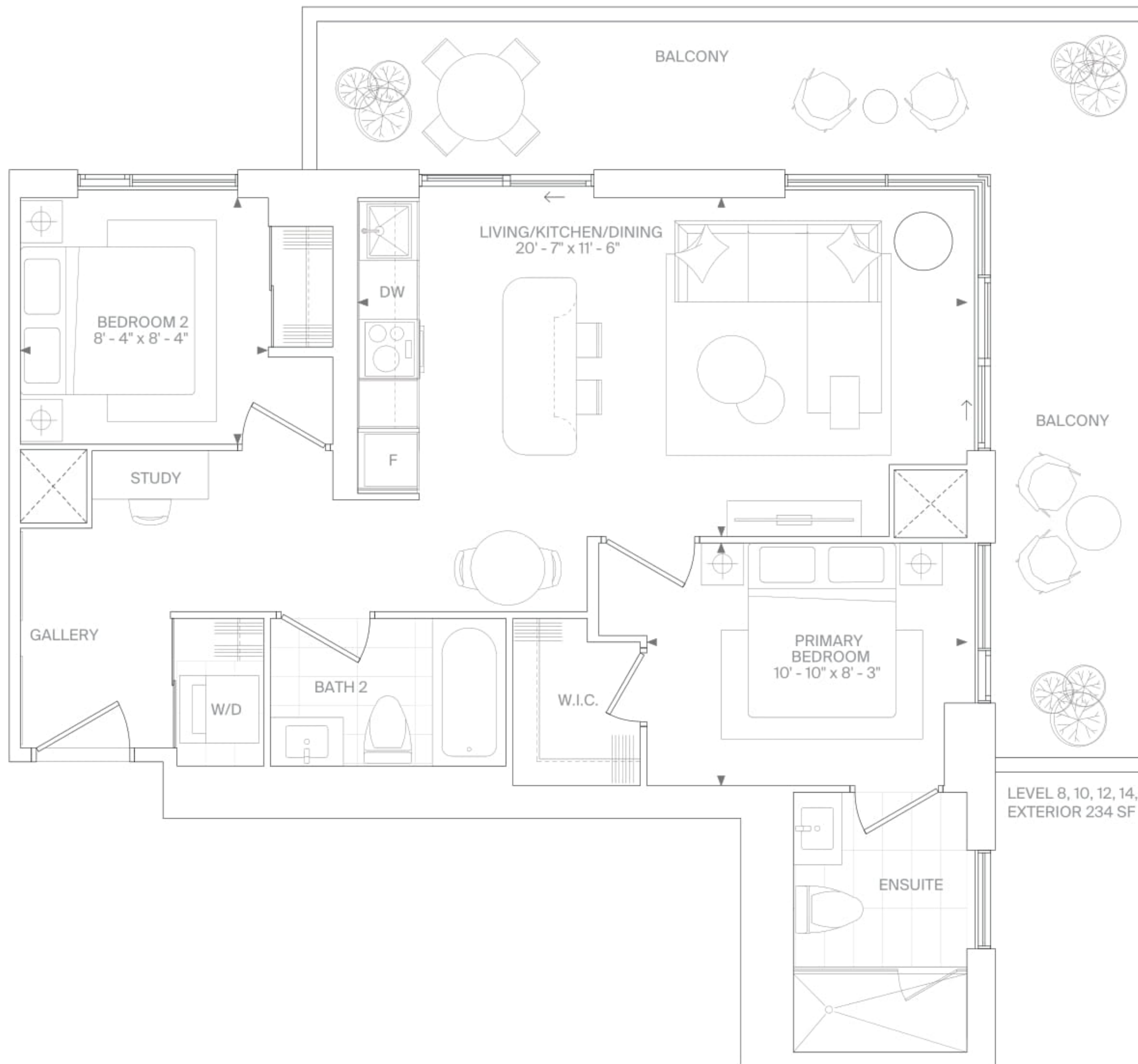

LEVEL 8, 10, 12, 14, 16, 18, 20, 22, 24, 28
EXTERIOR 234 SF

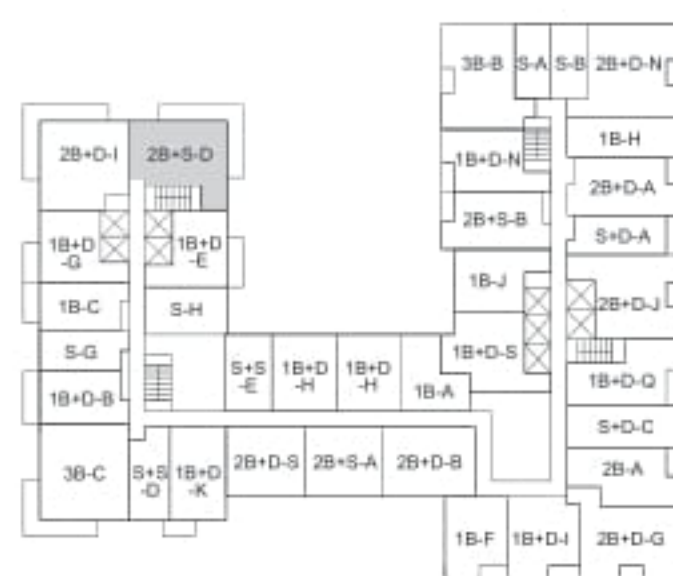

PODIUM LEVEL 8

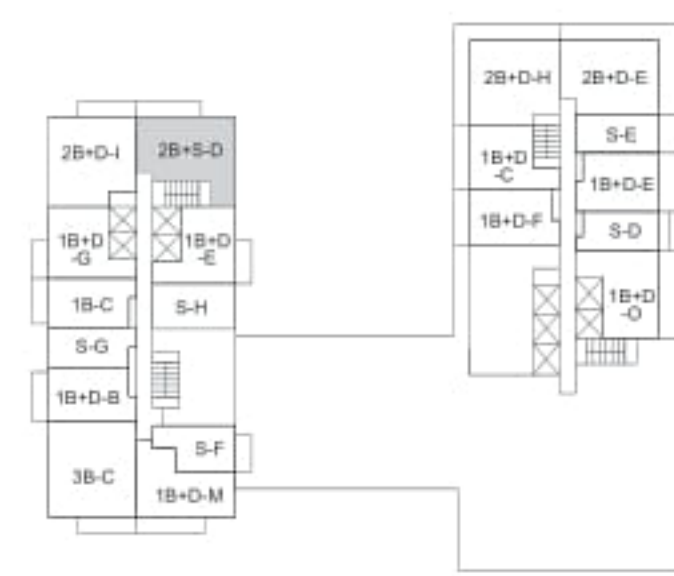

PODIUM LEVEL 9

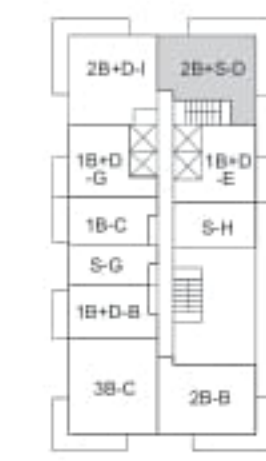

TOWER 2 LEVEL 10

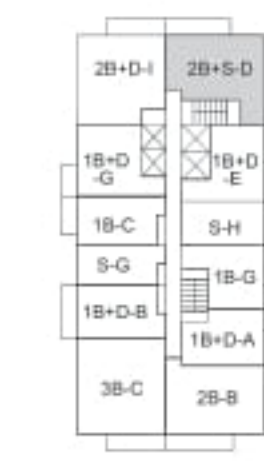

TOWER 2 LEVEL 11

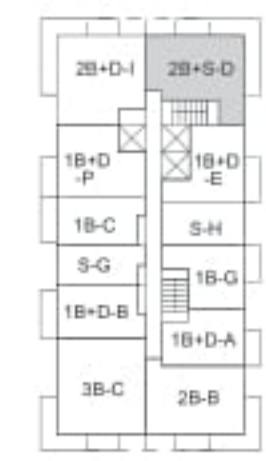

TOWER 2 LEVEL 12 - 29

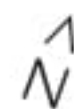

ALL DIMENSIONS AND SPECIFICATIONS ARE APPROXIMATE. CERTAIN PLANS ARE REVERSE OR MIRROR IMAGE. BALCONY SQUARE FOOTAGES ARE ESTIMATED AND MAY VARY FROM THAT STATED. PLEASE SEE SALES REPRESENTATIVE FOR DETAILS. FURNITURE NOT INCLUDED. REFER TO KEY PLAN FOR UNIT LOCATION AND ORIENTATION. PREPARED JUNE 9, 2022

2B+D-F

INTERIOR 809 SF | EXTERIOR 36 SF
2 BEDROOM+DEN, 2 BATH

FORÊT™

FOREST HILL

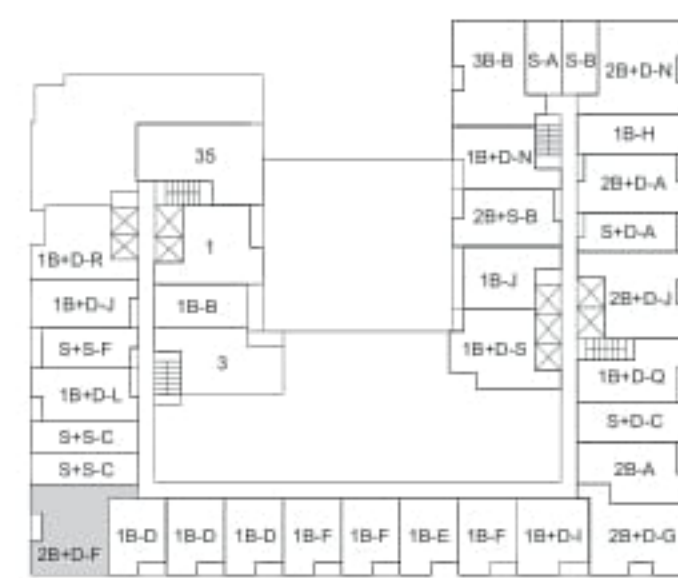
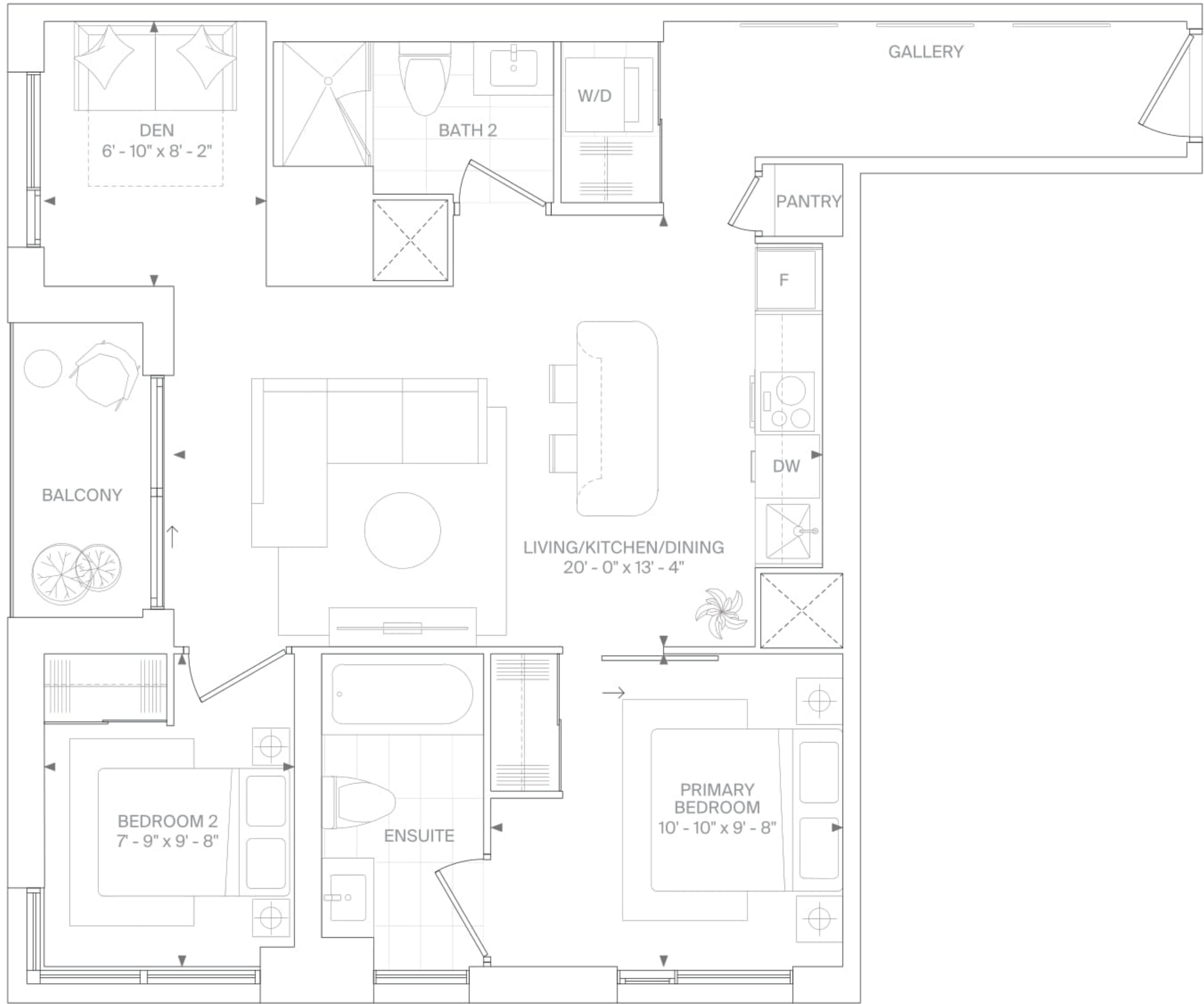

PODIUM LEVEL 2

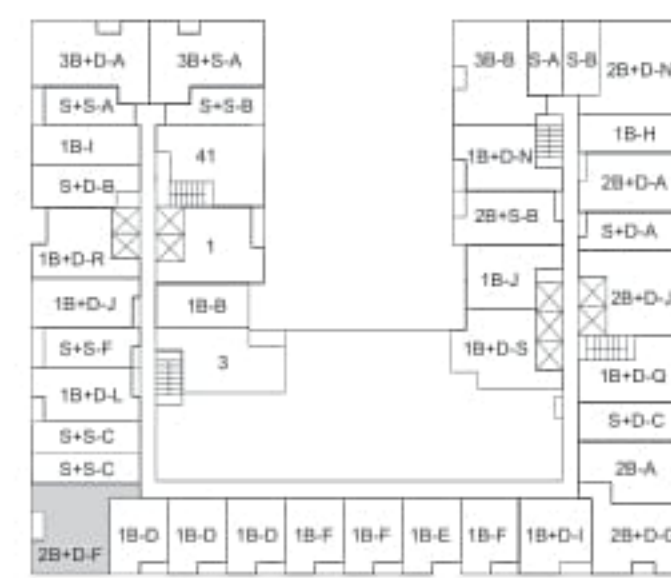

PODIUM LEVEL 3 - 5



ALL DIMENSIONS AND SPECIFICATIONS ARE APPROXIMATE. CERTAIN PLANS ARE REVERSE OR MIRROR IMAGE. BALCONY SQUARE FOOTAGES ARE ESTIMATED AND MAY VARY FROM THAT STATED. PLEASE SEE SALES REPRESENTATIVE FOR DETAILS. FURNITURE NOT INCLUDED. REFER TO KEY PLAN FOR UNIT LOCATION AND ORIENTATION. PREPARED JUNE 9, 2022

2B+D-K

INTERIOR 904 SF | EXTERIOR 163 SF
2 BEDROOM+DEN, 2 BATH

FORÊT™

FOREST HILL

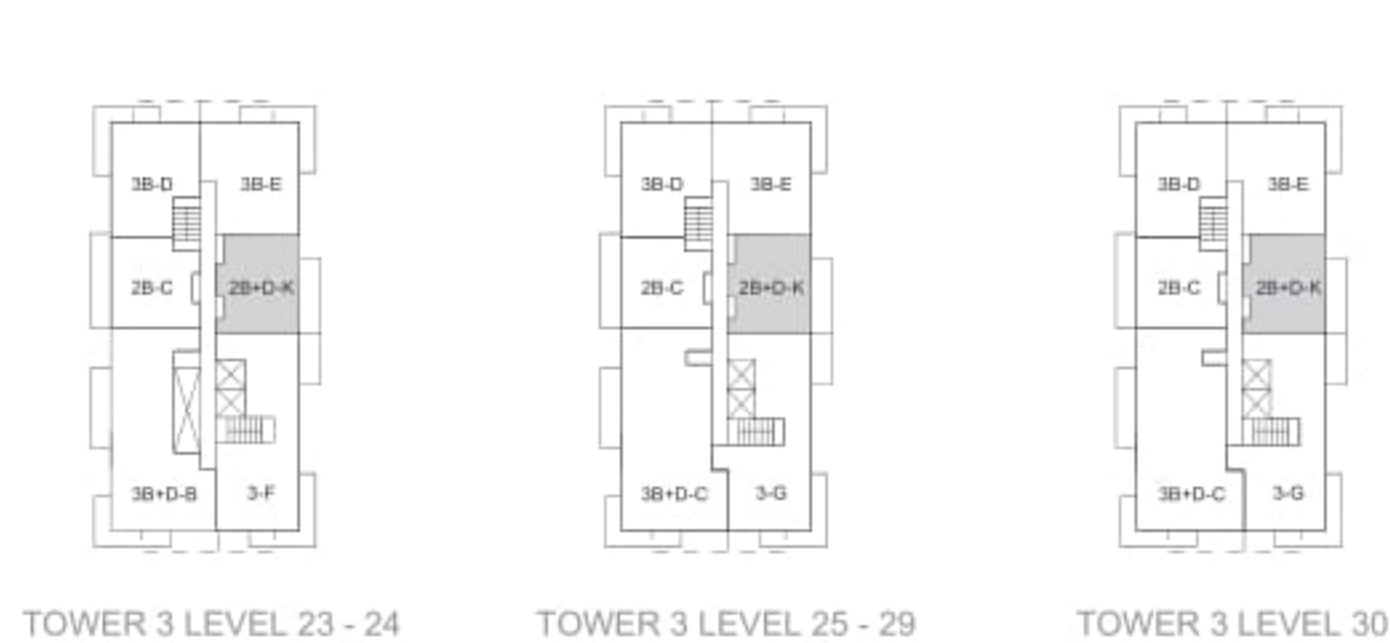

TOWER 3 LEVEL 23 - 24

TOWER 3 LEVEL 25 - 29

TOWER 3 LEVEL 30

ALL DIMENSIONS AND SPECIFICATIONS ARE APPROXIMATE. CERTAIN PLANS ARE REVERSE OR MIRROR IMAGE. BALCONY SQUARE FOOTAGES ARE ESTIMATED AND MAY VARY FROM THAT STATED. PLEASE SEE SALES REPRESENTATIVE FOR DETAILS. FURNITURE NOT INCLUDED. REFER TO KEY PLAN FOR UNIT LOCATION AND ORIENTATION. PREPARED JUNE 9, 2022

3B-C

FORÊT™

FOREST HILL

INTERIOR 990 SF | EXTERIOR 178 SF
3 BEDROOM, 2 BATH

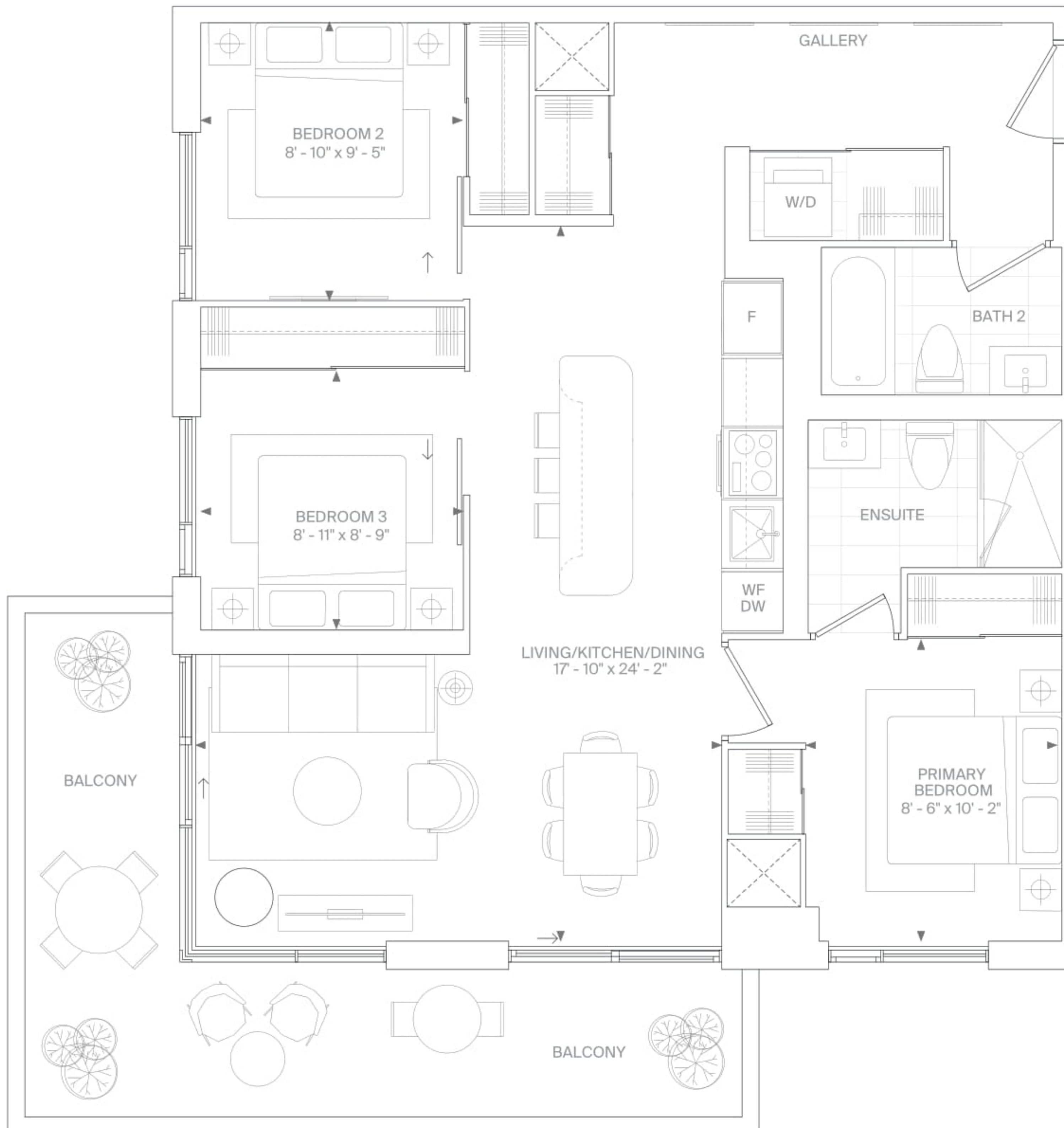

LEVEL 8, 10, 12, 14, 16, 18, 20, 22, 24, 26, 28 EXTERIOR 178 SF

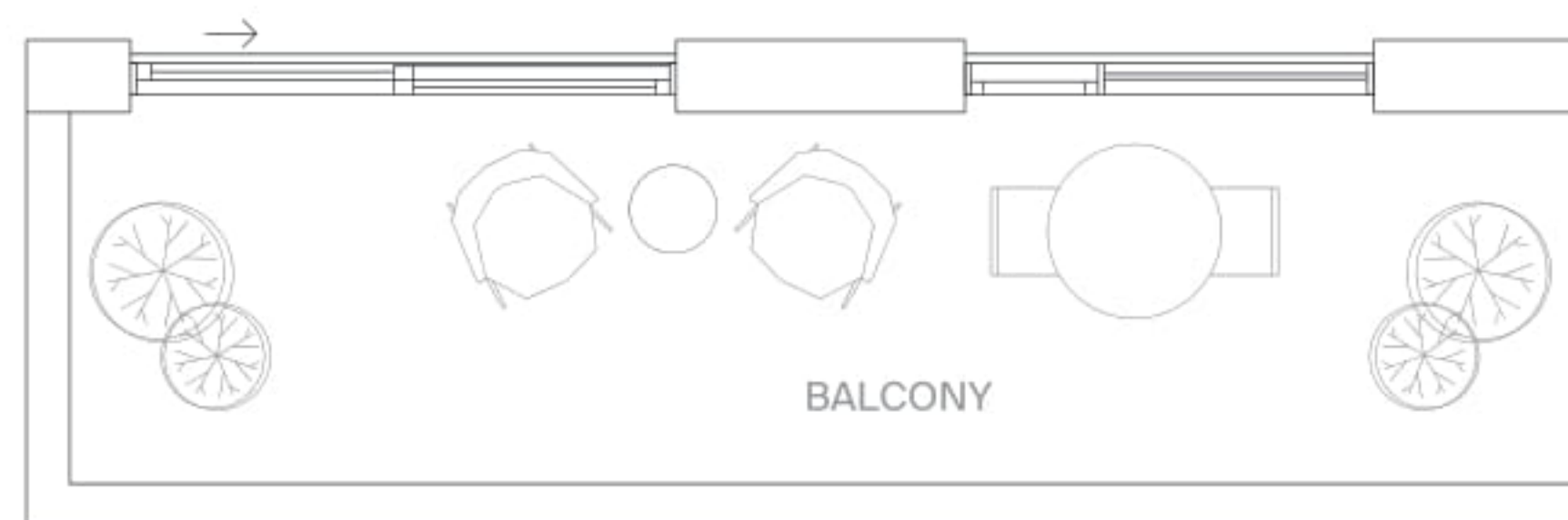

LEVEL 9, 11, 13, 15, 17, 19, 21, 23, 25, 27, 29 EXTERIOR 98 SF

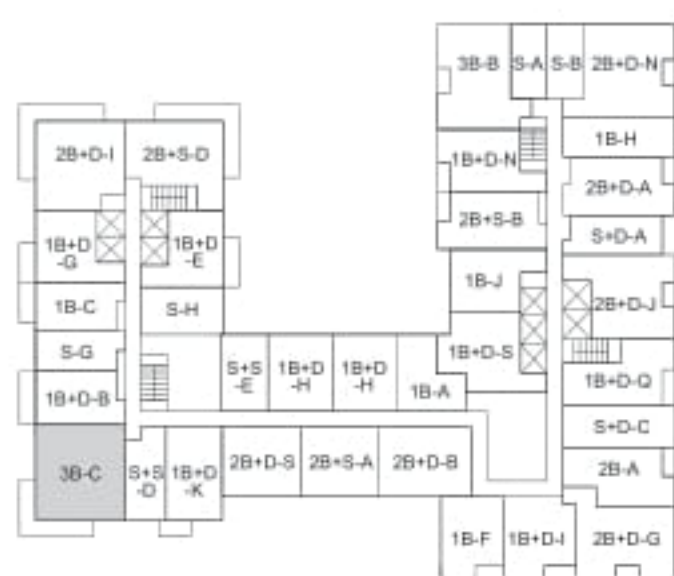

PODIUM LEVEL 8

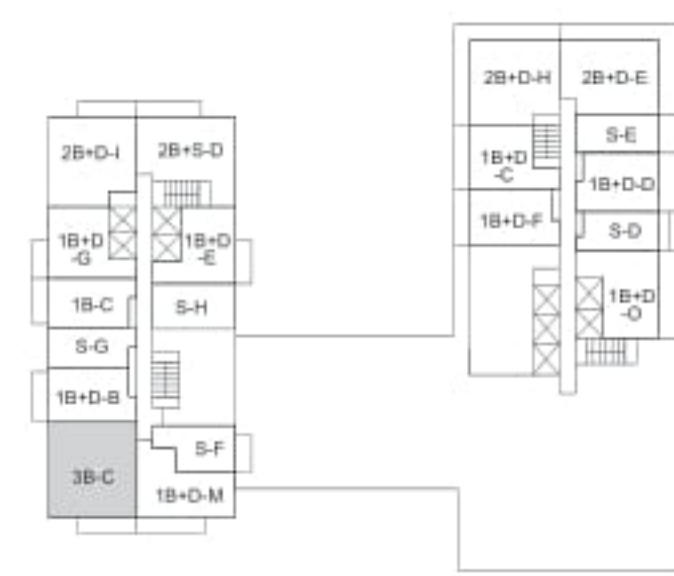

PODIUM LEVEL 9

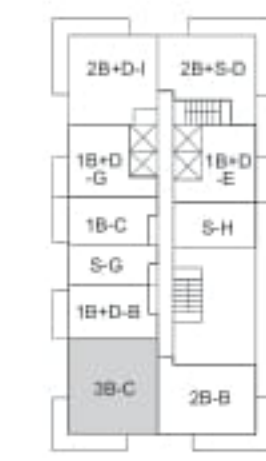

TOWER 2 LEVEL 10

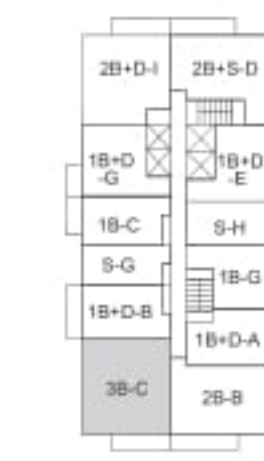

TOWER 2 LEVEL 11

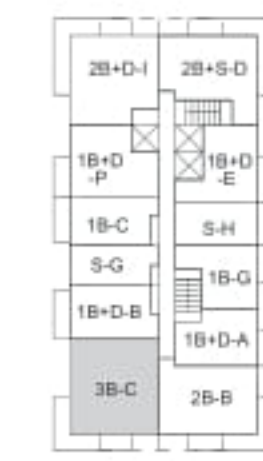

TOWER 2 LEVEL 12 - 29

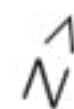

3B-D

INTERIOR 1088 SF | EXTERIOR 147 SF
3 BEDROOM, 2 BATH

FORÊT™

FOREST HILL

LEVEL 23, 25, 27, 29, 31 EXTERIOR 188 SF

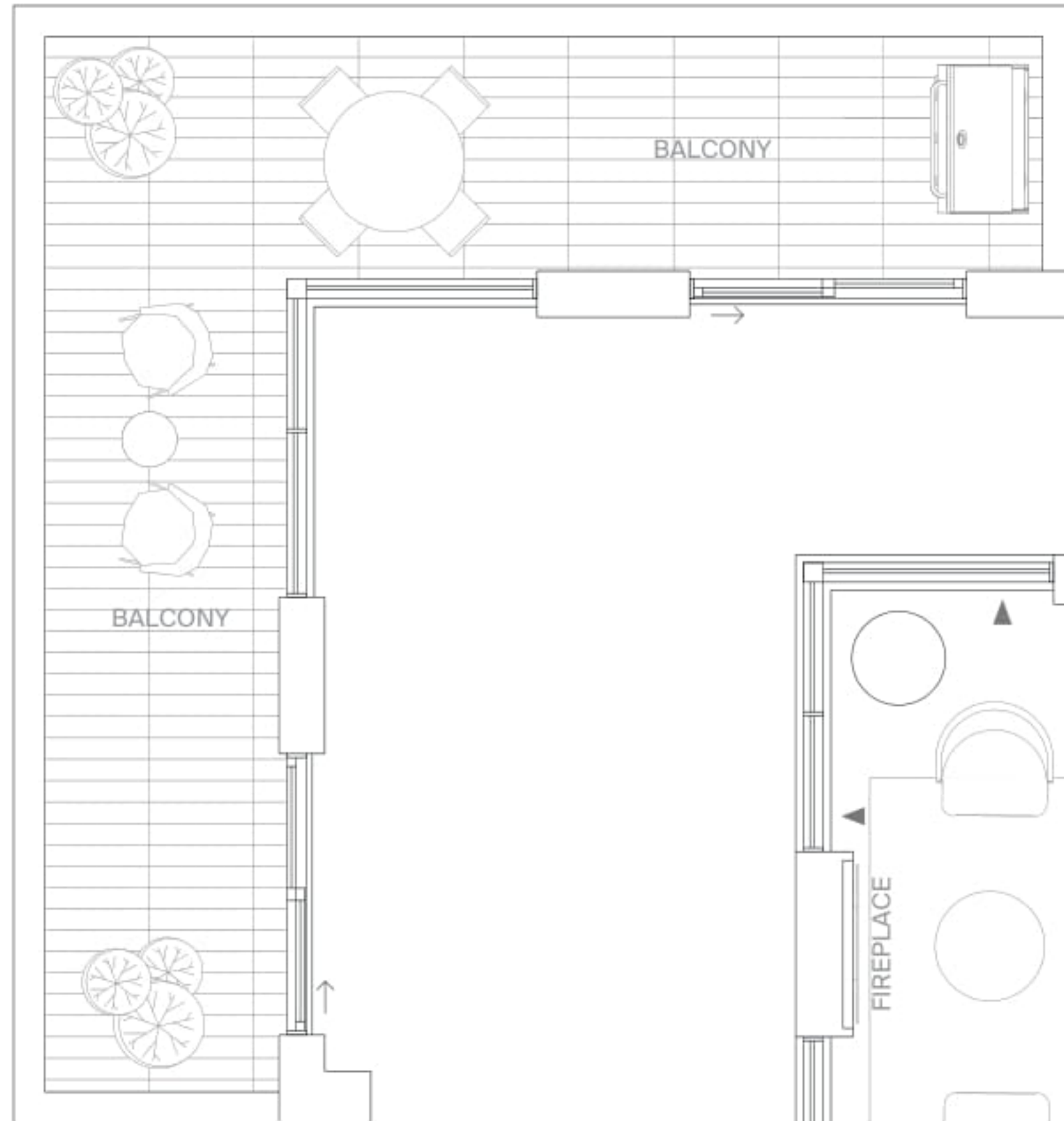

LEVEL 24, 26, 28, 30

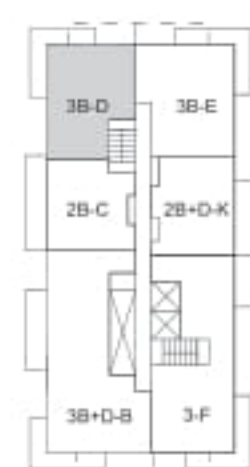
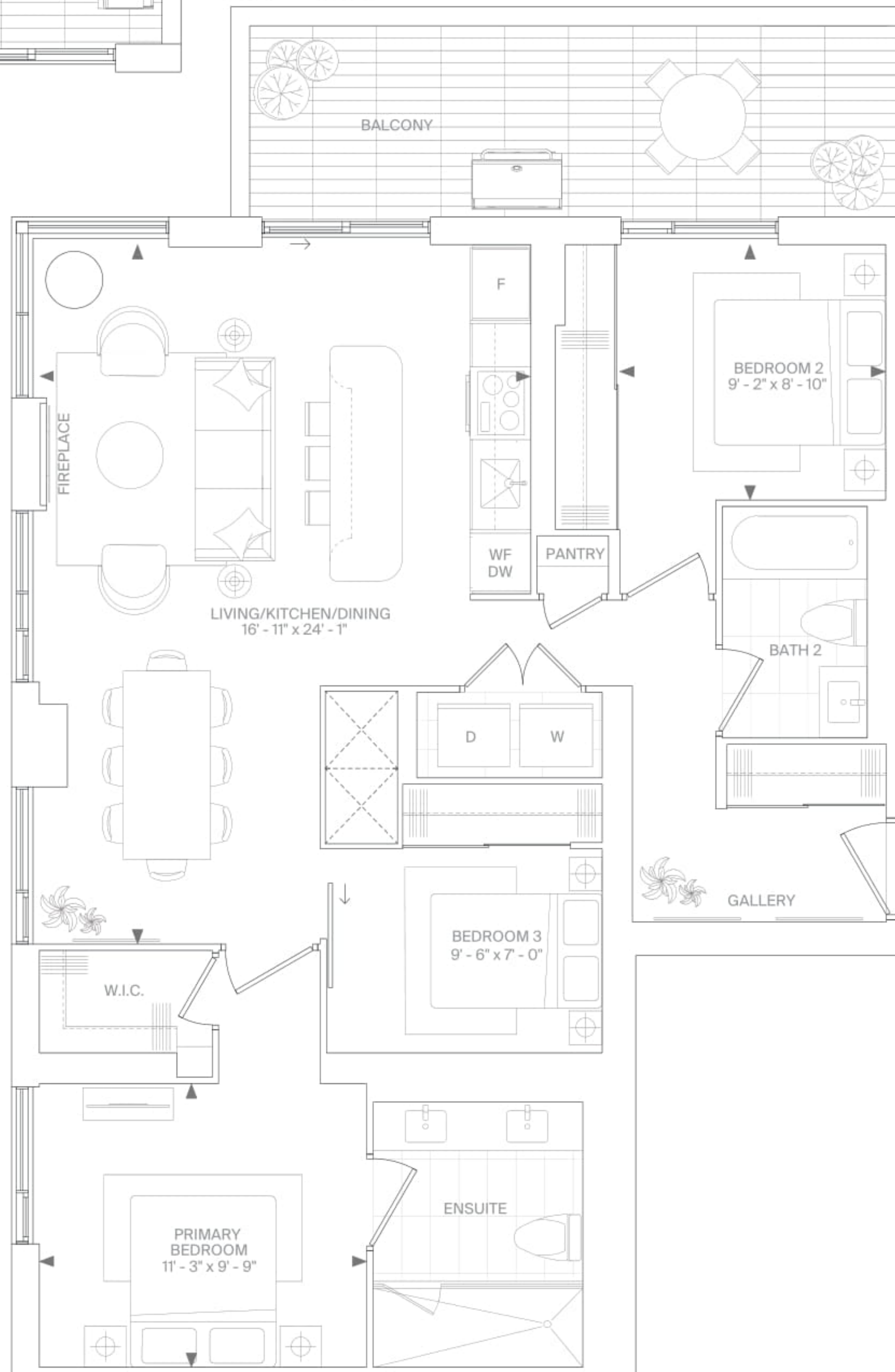

TOWER 3 LEVEL 23 - 24

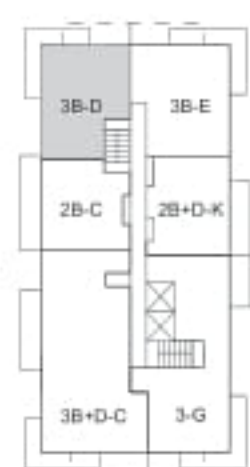

TOWER 3 LEVEL 25 - 29



TOWER 3 LEVEL 30



TOWER 3 LEVEL 31



ALL DIMENSIONS AND SPECIFICATIONS ARE APPROXIMATE. CERTAIN PLANS ARE REVERSE OR MIRROR IMAGE. BALCONY SQUARE FOOTAGES ARE ESTIMATED AND MAY VARY FROM THAT STATED. PLEASE SEE SALES REPRESENTATIVE FOR DETAILS. FURNITURE NOT INCLUDED. REFER TO KEY PLAN FOR UNIT LOCATION AND ORIENTATION. PREPARED JUNE 9, 2022

3B-E

INTERIOR 1196 SF | EXTERIOR 159 SF
 3 BEDROOM (BF), 2 BATH

FORÊT™

FOREST HILL

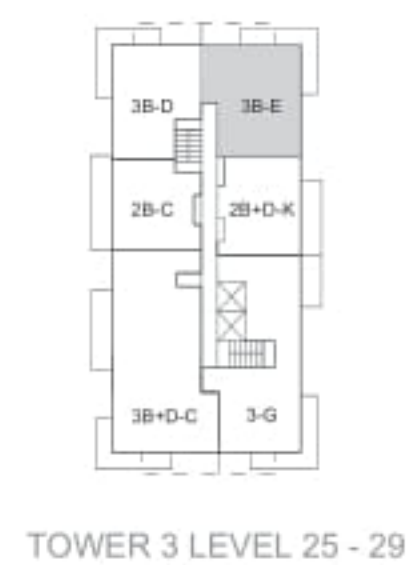
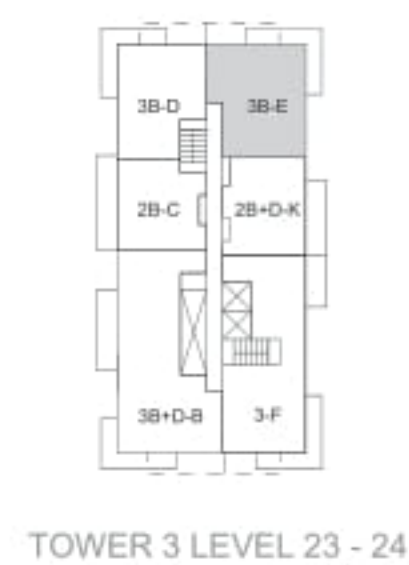
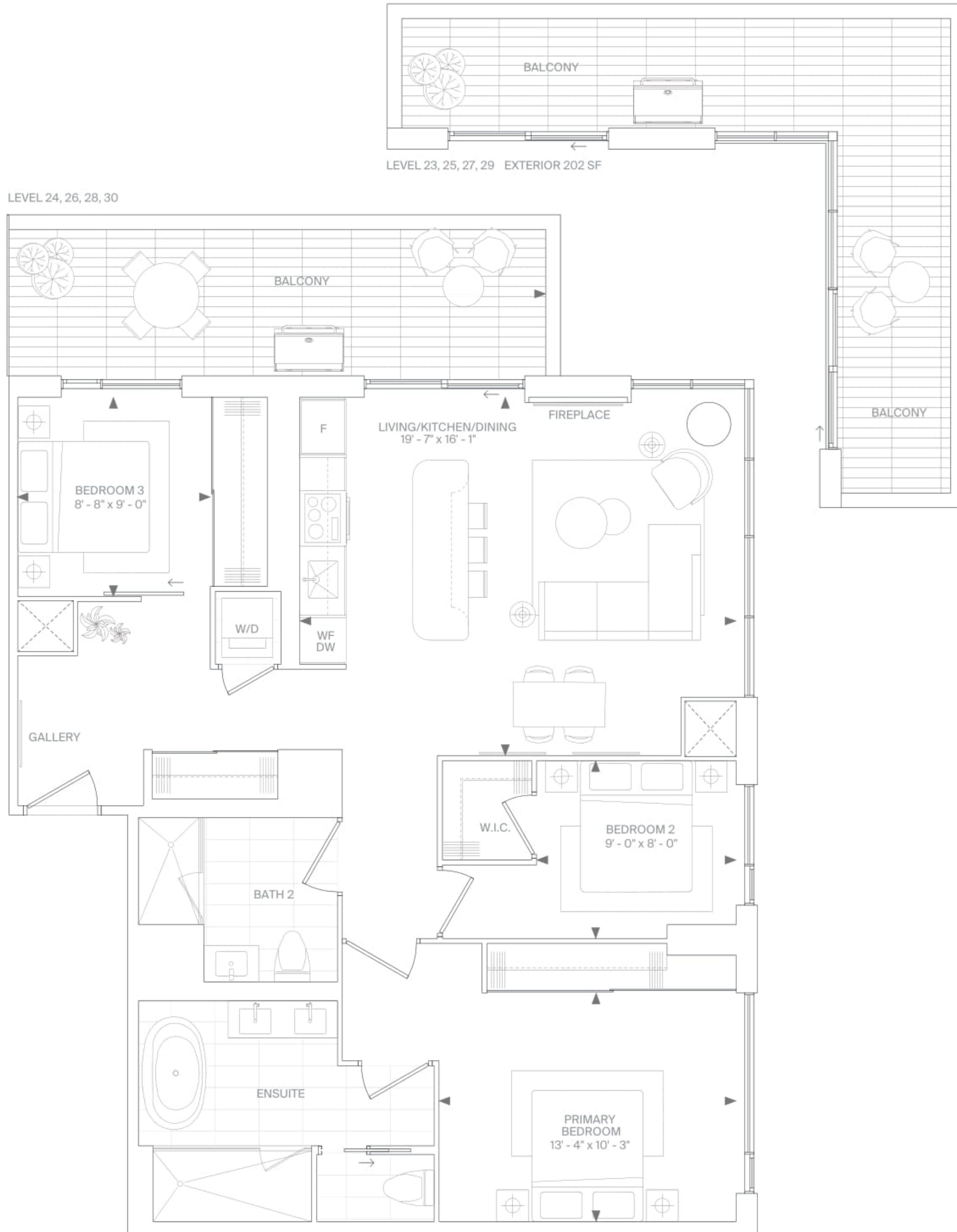

ALL DIMENSIONS AND SPECIFICATIONS ARE APPROXIMATE. CERTAIN PLANS ARE REVERSE OR MIRROR IMAGE. BALCONY SQUARE FOOTAGES ARE ESTIMATED AND MAY VARY FROM THAT STATED. PLEASE SEE SALES REPRESENTATIVE FOR DETAILS. FURNITURE NOT INCLUDED. REFER TO KEY PLAN FOR UNIT LOCATION AND ORIENTATION. PREPARED JUNE 9, 2022



3-F

INTERIOR 1540 SF | EXTERIOR 311 SF
 2 BEDROOM+DEN/FAMILY, 3 BATH

FORÊT™

FOREST HILL

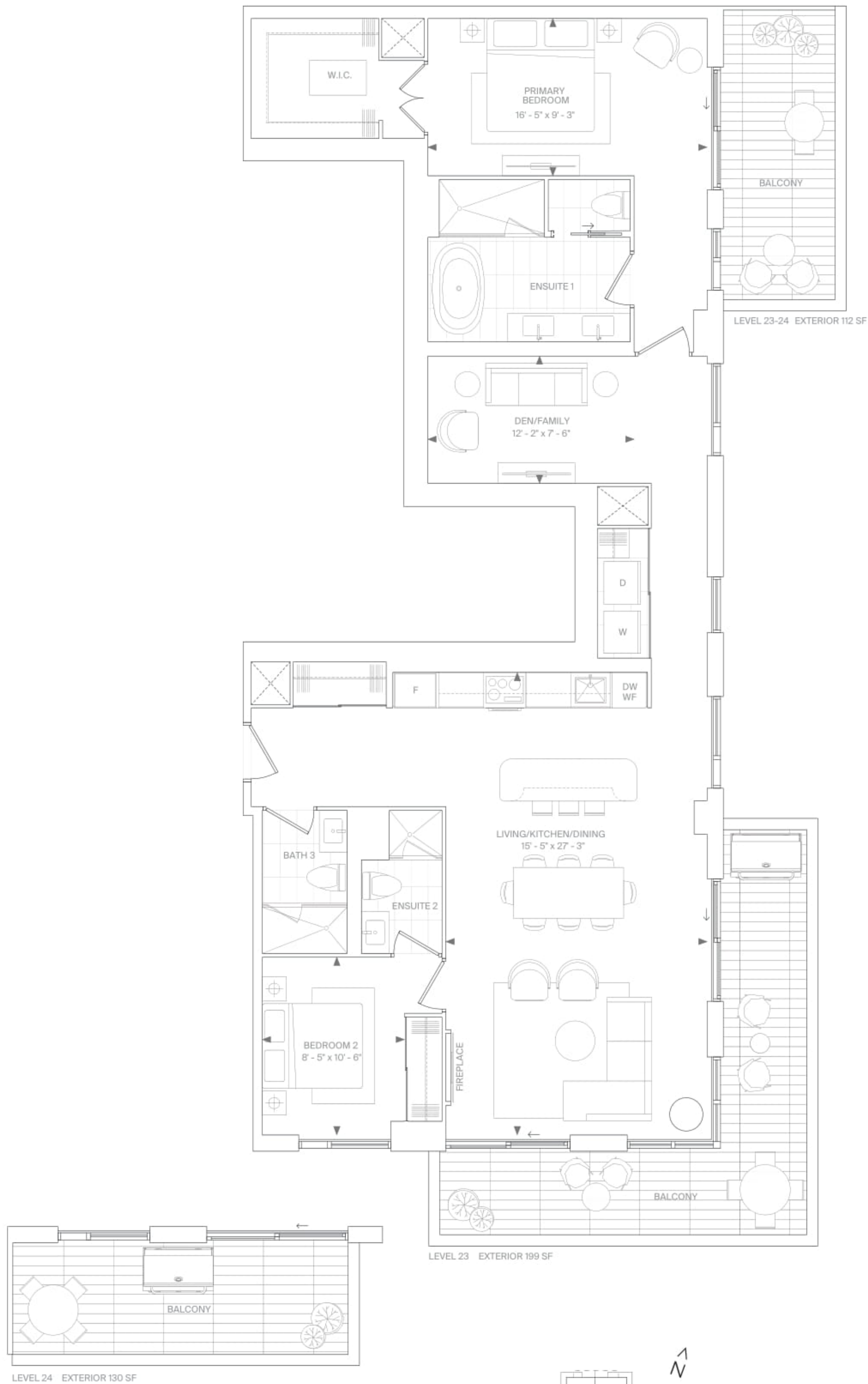

ALL DIMENSIONS AND SPECIFICATIONS ARE APPROXIMATE. CERTAIN PLANS ARE REVERSE OR MIRROR IMAGE. BALCONY SQUARE FOOTAGES ARE ESTIMATED AND MAY VARY FROM THAT STATED. PLEASE SEE SALES REPRESENTATIVE FOR DETAILS. FURNITURE NOT INCLUDED. REFER TO KEY PLAN FOR UNIT LOCATION AND ORIENTATION. PREPARED JUNE 9, 2022

3B+S-A

INTERIOR 915 SF | EXTERIOR 32 SF
3 BEDROOM+DEN, 2 BATH

FORÊT™

FOREST HILL

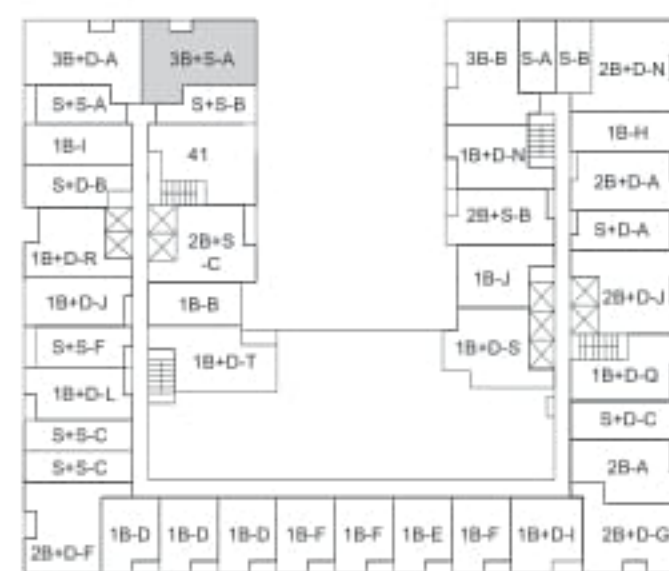
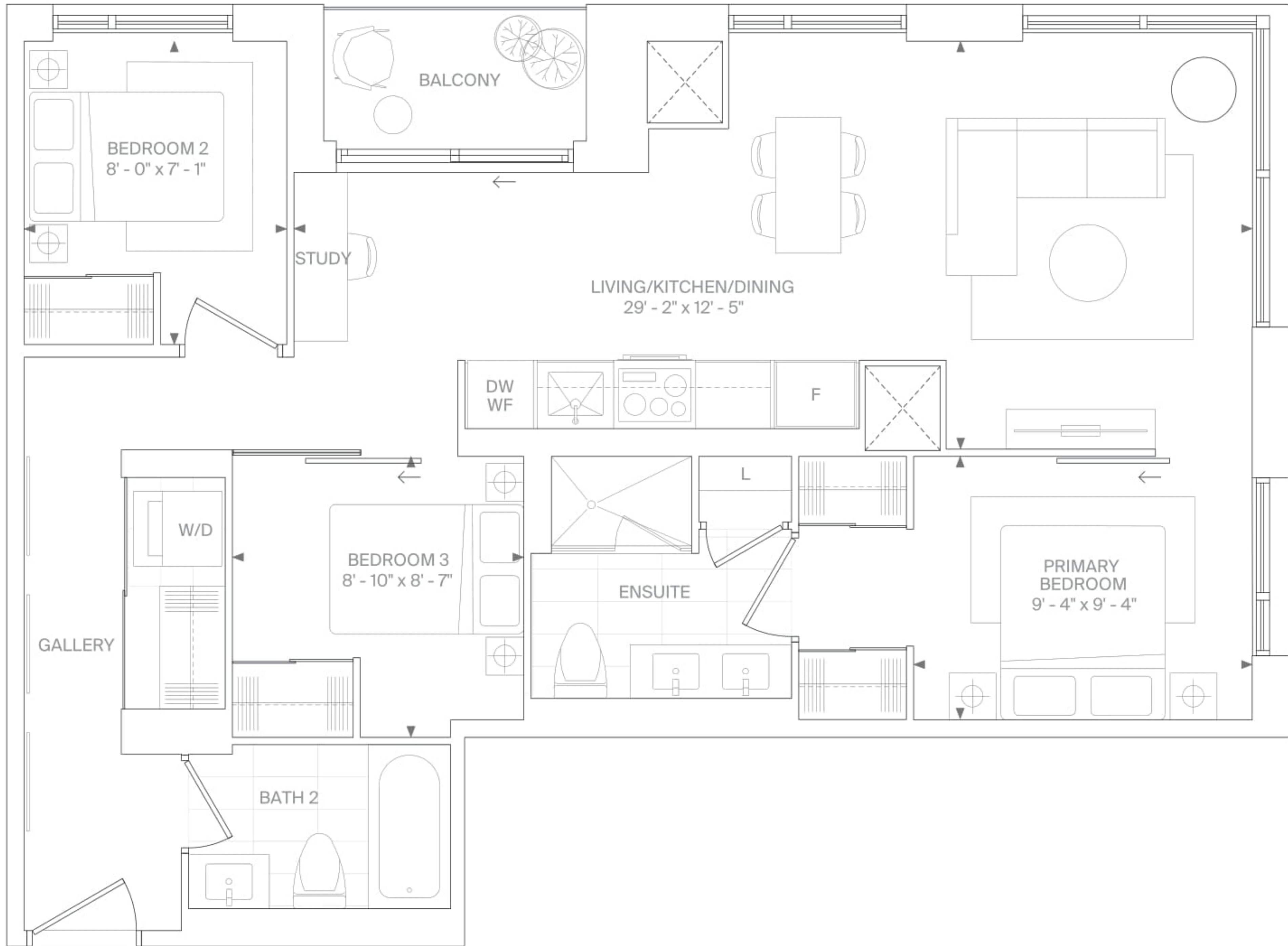

PODIUM LEVEL 3 - 5

ALL DIMENSIONS AND SPECIFICATIONS ARE APPROXIMATE. CERTAIN PLANS ARE REVERSE OR MIRROR IMAGE. BALCONY SQUARE FOOTAGES ARE ESTIMATED AND MAY VARY FROM THAT STATED. PLEASE SEE SALES REPRESENTATIVE FOR DETAILS. FURNITURE NOT INCLUDED. REFER TO KEY PLAN FOR UNIT LOCATION AND ORIENTATION. PREPARED JUNE 9, 2022

3B+D-A

INTERIOR 915 SF | EXTERIOR 33 SF
 3 BEDROOM+DEN (BF), 2 BATH

FORÊT™

FOREST HILL

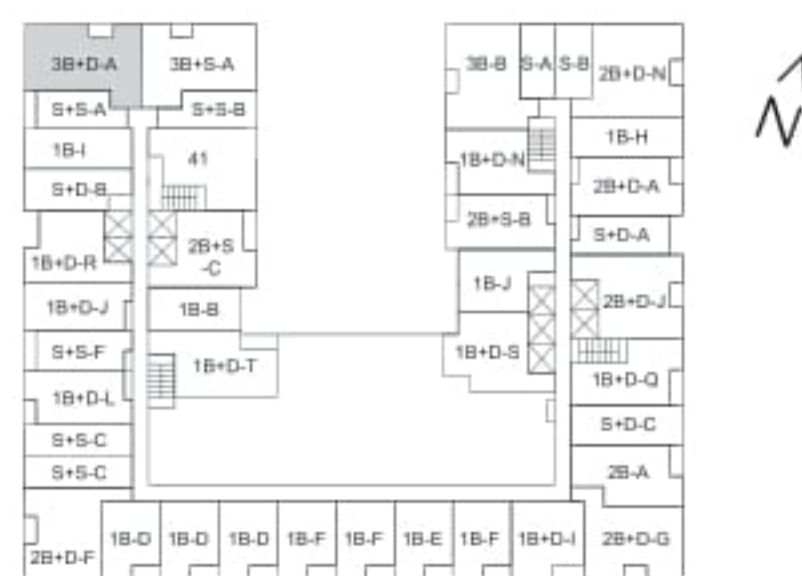
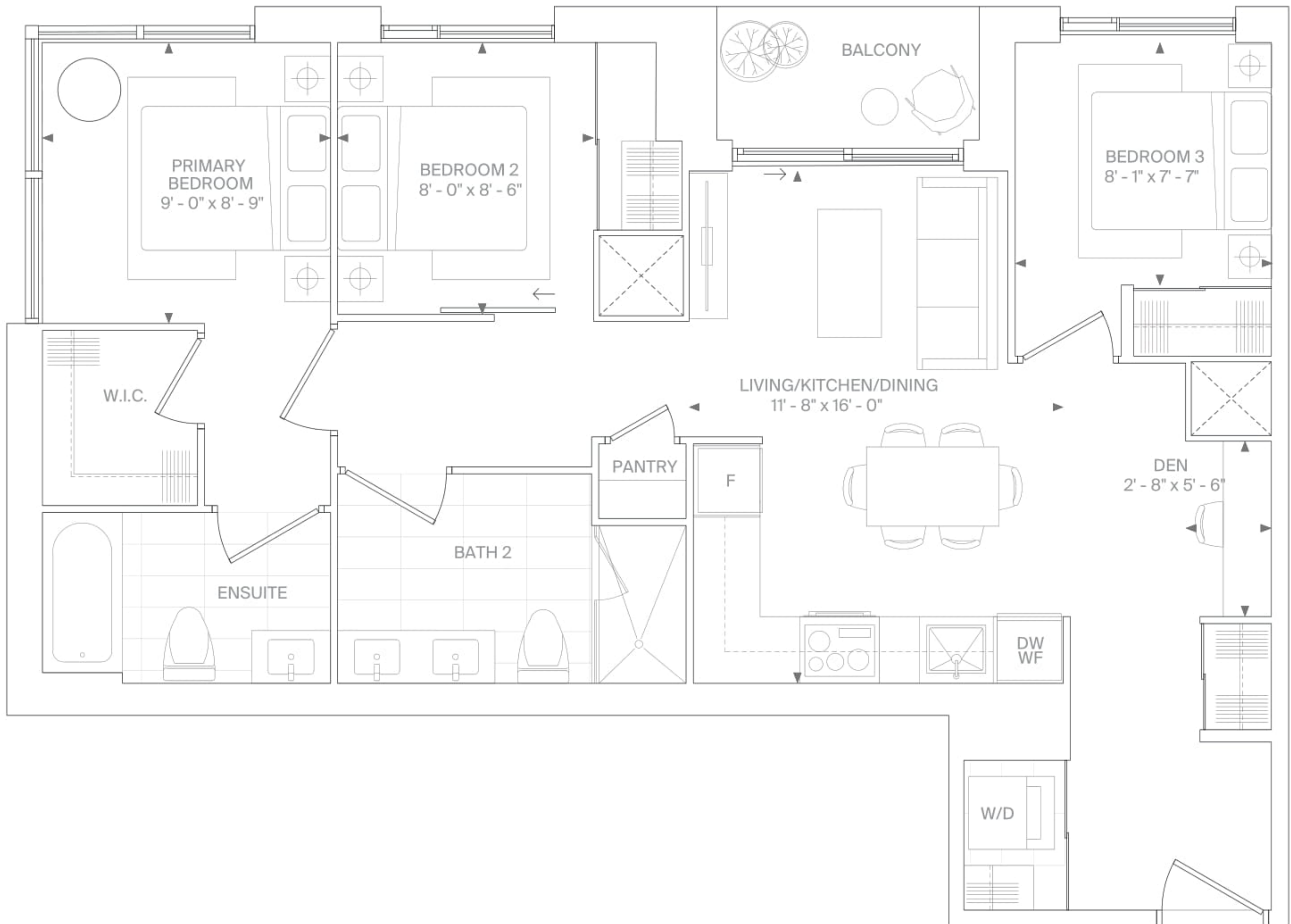

ALL DIMENSIONS AND SPECIFICATIONS ARE APPROXIMATE. CERTAIN PLANS ARE REVERSE OR MIRROR IMAGE. BALCONY SQUARE FOOTAGES ARE ESTIMATED AND MAY VARY FROM THAT STATED. PLEASE SEE SALES REPRESENTATIVE FOR DETAILS. FURNITURE NOT INCLUDED. REFER TO KEY PLAN FOR UNIT LOCATION AND ORIENTATION. PREPARED JUNE 9, 2022

3B+D-B

INTERIOR 1923 SF | EXTERIOR 350 SF
 3 BEDROOM (BF), 3 BATH

FORÊT™

FOREST HILL

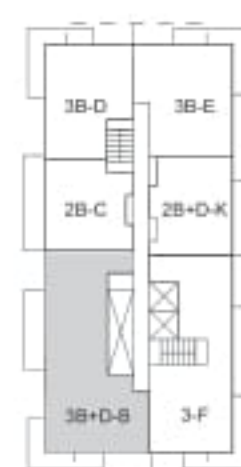
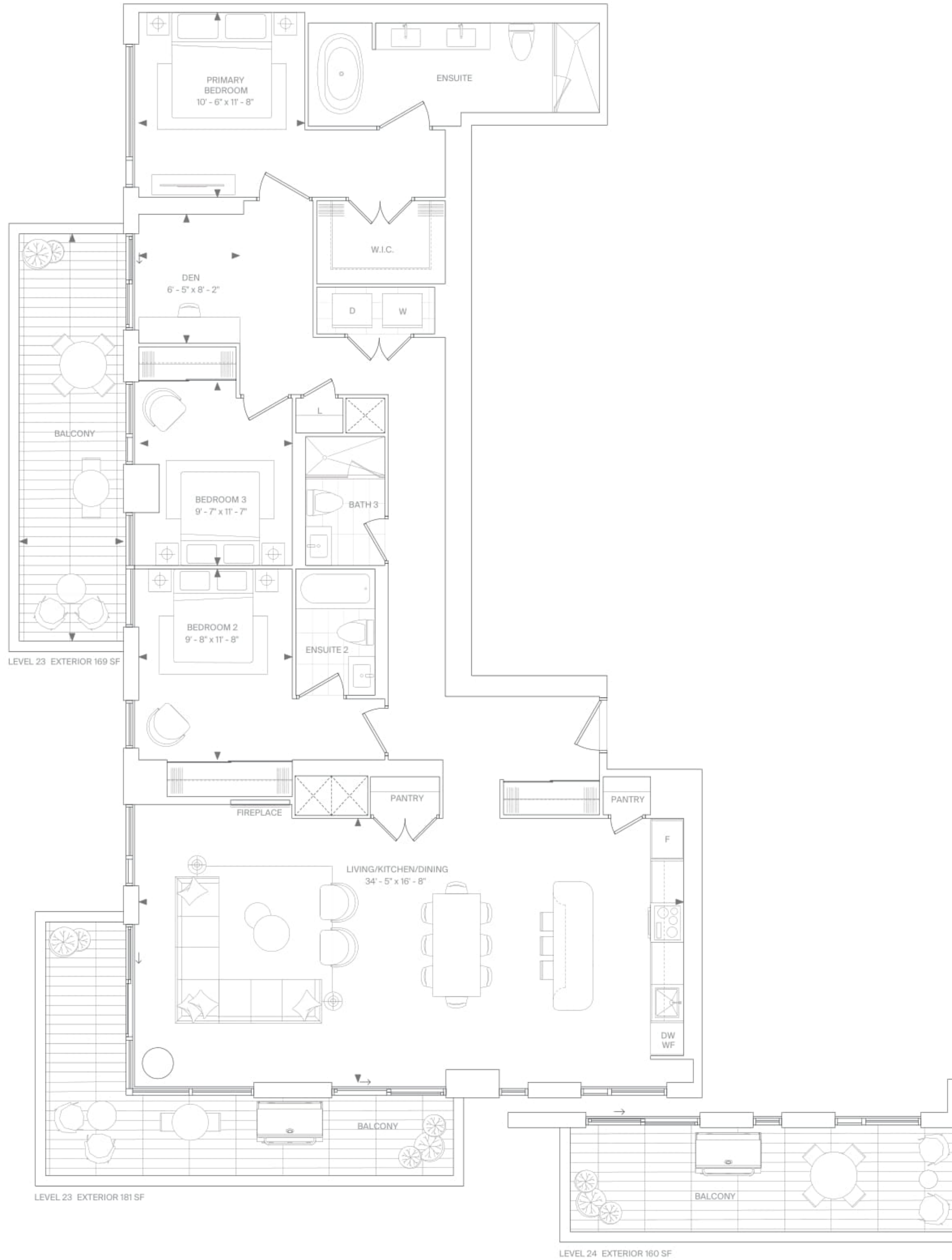

TOWER 3 LEVEL 23 - 24

ALL DIMENSIONS AND SPECIFICATIONS ARE APPROXIMATE. CERTAIN PLANS ARE REVERSE OR MIRROR IMAGE. BALCONY SQUARE FOOTAGES ARE ESTIMATED AND MAY VARY FROM THAT STATED. PLEASE SEE SALES REPRESENTATIVE FOR DETAILS. FURNITURE NOT INCLUDED. REFER TO KEY PLAN FOR UNIT LOCATION AND ORIENTATION. PREPARED JUNE 9, 2022